

S38.3115 Signaling Protocols – Lecture Notes

Lecture 9 – Mobility Management and Mobile Application Part (MAP)

Introduction.....	2
Mobility problem analysis	2
Location of users.....	2
GSM solution of mobility management for circuit switching	5
Reasonable cell size	6
GSM mobility solution for packet services	8
Background on IP networks.....	8
Mobile IP	9
GPRS solution for mobility	9
GPRS mobility state model.....	10
Summary of GPRS mobility solution	11
Introduction to MAP	12
MAP development roadmap	13
MAP services model	14
The environment of MAP	15
Addressing in MAP.....	15
A view from above.....	16
A view from underneath: MAP uses TCAP	16
Data in HLR.....	16
Mobility management support in MAP	17
Location Management in MAP.....	17
Location of user in Mobile Terminated call	18
Triangular routing in GSM	19
Handover from one MSC to another MSC	19
Security operations in MAP	21
Subscriber management operations	21
Network requested PDP context activation	22
Supplementary services operations in MAP	22
Short Message service support in MAP	23
Short Message protocol stack	24
MO SMS service.....	25
MT SMS Service.....	25
Role of HLR in SMS service	26
Other MAP services	27
Call Completion to Busy Subscriber.....	27
Unstructured Supplementary Service Data	28

Introduction

Mobility management allows mobile users to make use of network services and be reachable to other communication parties while they move around.

There are several aspects to mobility. We talk about *terminal mobility* referring to the fact that the terminal moves under the coverage area of the network or between networks. Similarly, we talk about *user mobility*. *Service mobility* refers to a phenomenon of moving between networks of different or the same type while a service is being used. The particular feature of mobility that users can move to networks owned by a different administration than their home network is called *roaming*.

Mobility can be seamless or not. Mobility is seamless when service quality does not suffer when the device moves from one area to another or from one network to another.

Mobility management for voice services has proven to be very valuable. Users are quite willing to pay higher prices for mobile service than for a fixed service. Mobility management is also quite complex. This is proven by the fact that actually only a handful of companies have been able to create a rich and successful portfolio of products supporting mobile communication services.

MAP is the protocol that provides the mobility management for GSM and 3G networks. Other solutions for mobility management mainly data protocol driven such as Mobile IP have been proposed as well. None of them at least so far come even close in value to mobility management in GSM and 3G based on MAP. *MAP provides the additional core network signaling capability that is needed besides ISUP because of the fact the access is based on radio and the fact that users can move around with their mobile stations.*

Mobility problem analysis

Let us first discuss the nature of the technical problem of mobility and try to browse the solutions space.

Location of users

The location of users in networks is based on directory numbers. When discussing wire line services we already noted that actually switching systems assume that dialed digits form *routable numbers* that are nicely aligned with the network topology. Such numbers are allocated to network nodes block by block and the block size may be for example 1000 numbers. How numbers are actually analyzed? We depict the process of number analysis in Figure 9.1

The tree in Figure 9.1 is schematic only. Each box is a node taking for example $4 \times 16 = 64$ octets of memory. This would assume that a pointer takes 4

octets and that digits from 0 to F can be analyzed by looking up the corresponding pointer in the node.

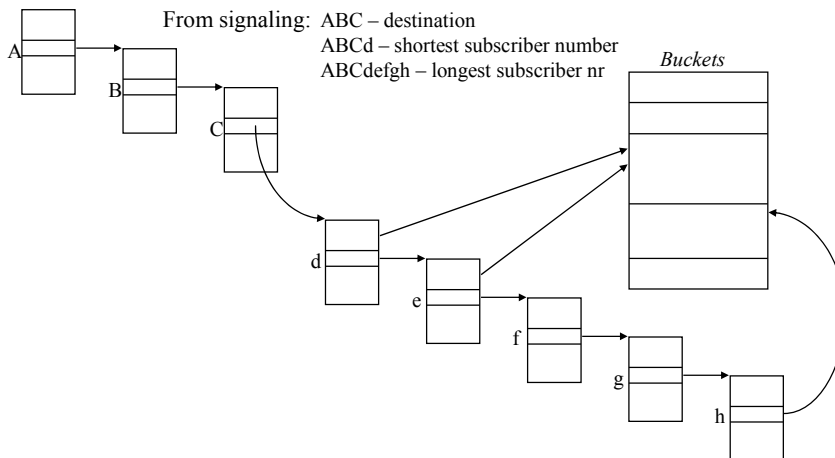

Figure 9.1: A number analysis tree.

If the number to be analyzed is ABCdefgh (i.e. 8 digits) the analysis starts by looking up the entry against A in the root node. A pointer is found to the next level node in which the second digit B can be analyzed. The analysis progresses through the tree, on each step one digit is consumed and a new node is found until the analysis ends and the pointer actually points to a bucket file housing the results.

Let us denote the number of values that appear in each position of the number by v_1, v_2, \dots, v_n . The size of the tree is:

$$\text{Size} = 64 \times (1 + v_2 + v_2 \times v_3 + v_2 \times v_3 \times v_4 + \dots + v_2 \times \dots \times v_{n-1} \times v_n). \quad [1]$$

To make things a bit simpler let us assume that in each position the number of used values is the same and equals to m . This is the average branching factor of the tree.

The number of nodes in the tree then equals to:

$$N_{\text{nodes}} = 1 + m + m^2 + \dots + m^{n-1} = (m^n - 1)/(m - 1). \quad [2]$$

The reason we introduce m and do not assume that all numbers are actually in use is simple. Turns out telephone numbering spaces are typically quite sparsely used. A typical feature of telephone numbering of variable length is that two numbers of the form:

ABCd and ABCDdx

can not appear in the same numbering system, i.e. a short number always consumes a big block of numbers if fixed length numbers with a uniform number of digits is taken for comparison.

The number of mobile users is 3.5 Billion at the moment. Let us assume that about 3 digits are used for country code, 2 or 3 for operator code and 7 for subscriber numbers. On average this gives

$$m^{12\dots13} = 3,5 \times 10^9 \Rightarrow (12 \dots 13) \lg m = 9 + \lg 3,5 \Rightarrow m \approx 5,4\dots6,2. \quad [3]$$

So, on average 5 to 7 digit values are used in each position of the directory numbers.

Assuming that $m = 5$ and the number length is 13 digits, the number of nodes in the analysis tree is about 300 million. The size of the analysis tree would be about 20 GBytes.

A few years ago this in itself would have been a problem. Moore's law has taken care of it. Today one can easily build a computer with a main memory of this size. The difficulty lies elsewhere.

Let us assume that mobile stations are let to move around and all exchanges are as in the wire line network with the difference that they have more memory and will analyze numbers till the last digits in their memory. The number of memory references for analyzing one number grows from about 4 till more than 10. This is not a problem.

The problem with this approach lies in the fact that there are a lot of exchanges that would need to know about the whereabouts of all mobile users. Assuming that one MSC takes care of 200 000 users on average, there are some 17 500 MSCs in the world dealing with 3.5 Billion users. In this architecture each MSC would need to know the location of every mobile user with some accuracy.

Assuming that each location update takes 50 bytes of signaling, the signaling towards each node is depicted in Figure 9.2. For the purpose of ensuring integrity of the location information we would have to repeat the location updates on regular intervals. Even if nodes would be rather big, we would probably need several updates per day for each user. An added trouble is that the size of the tree keeps growing in every node even if the particular operator is not getting any new customers. Most of the entries are useless for any given operator – they relate to users that no one of the local users knows!

Clearly this architecture must be abandoned because it does not scale to billions of users.

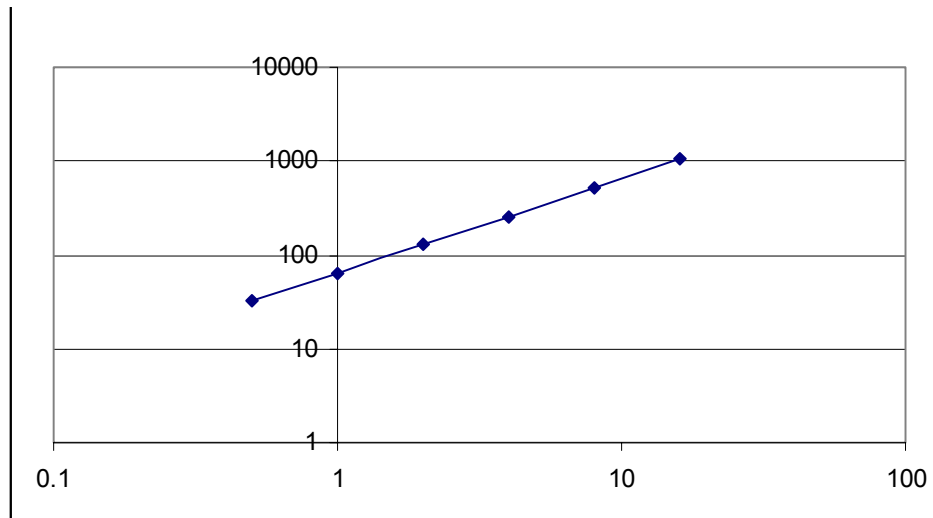

Figure 9.2: Hypothetical location update traffic

GSM solution of mobility management for circuit switching

In our description, at first, we will ignore number portability that is a recent addition to the original design. The discussion in the previous section shows that in order to achieve scalability, the problem of mobility management must be broken down into smaller problems. GSM does this in several ways.

First, instead of routing on directory numbers directly to a mobile destination, GSM locates the HLR of the mobile destination based on the MSISDN (i.e. the directory number of the callee). The HLR has earlier learned or will then learn dynamically the Mobile Subscriber Routing Number (MSRN) from the Visitor Location Register where the Mobile is currently visiting. The HLR will return the MSRN to the requesting Gateway MSC. From this point onwards, the GMSC and any transit exchanges are able to use the MSRN to route the call to the visited MSC using just the leading digits of the MSRN. Only the vMSC will need to look at the tail of the MSRN.

Second, the number of location updates to the HLR is reduced by telling the HLR not about every cell change but rather about the changes from the responsibility area of one VLR to the responsibility area of another VLR. Location updates to the VLR tell about the changes *from one location area to another*. Location areas (LA) are continuous areas of cells. Because of the LA concept for terminating calls Mobile Stations must be paged by sending the call in every cell of the LA. The Mobile will respond in the cell that it evaluates as the best for itself.

Mobile stations may be switched off or go out of coverage. Therefore, also *periodic location updates* are needed. The period is something between once/6 min and 24h.

Let us estimate the amount of location update traffic towards an HLR responsible for 200000 subscribers. Let us assume that the update takes 200 bytes of signaling and an update takes place once in 5min for each subscriber. The amount of location update traffic is:

$$\text{Traffic} = 200 \times 8 \times 200\,000 / (5 \times 60) \text{ bits} \approx 1 \text{ Mbit/s.}$$

This can be carried over a single PCM line assuming a dimensioning of about 0.5 Erlang per traffic channel. This seems quite feasible.

Note also that the MSISDN/MSRN mapping needs to be maintained in two places: the HLR and the VLR where the user is visiting. The rest of the network does not need know about the individual MSISDN and MSRNs. The rest of the nodes need to know just about the leading digits of both.

Using formula [2], we show the number of nodes as a function of n , when $m=6$ in Table 9.1.

m	n	nrof nodes
6	10	12 093 235
6	9	2 015 539
6	8	335 923
6	7	55 987
6	6	9 331
6	5	1 555

Table 9.1: Sizing the analysis tree.

There are less than 1000 operators and less than 400 countries. By routing first to countries based on country codes and once the call arrives into the country to the operator, we can estimate that the rather fixed tree for the leading digits will take a few thousand nodes. Updates to this part of the analysis tree are needed only on numbering changes concerning large amounts of subscribers.

Reasonable cell size

What is a reasonable size of a cell? We can reason that if cells are very small, a lot of them are needed to cover a large area. The number of cells required grows relative to the square of the radius of cells. Backhaul transmission from small base stations will be costly. Also if cells are small a fast moving vehicle with several mobiles will be difficult to handle and will create a lot of location update traffic. On the other hand if cells are very large, network capacity will become a problem. It would seem that the optimum lies somewhere in between

very small radius and large radius. Cell size must be small enough to create the required level of capacity but not smaller. The number of location updates can be further reduced by having several layers of cells of different sizes and trying to place fast moving Mobile Stations in large cells and stationary Mobile Stations in small cells. The idea must be supported by handovers between the two.

One aspect of a reasonable cell size is the number of cell updates created by moving mobiles. We depict this variable in Figure 9.3. It shows the number of cell changes¹.

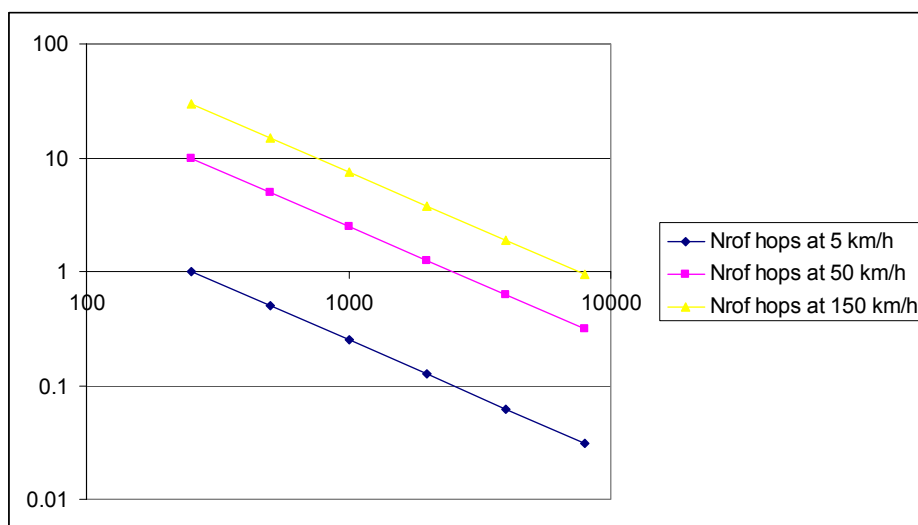

Figure 9.3: Number of cell hops at speed of 5, 50 and 150 km/h as a function of cell diameter.

The Figure shows that at the design speed of GSM which is up to 150 km/h, the system must have cells with a diameter of more than 7 km in order to keep the average number of location updates per 3 min call at the level of less than 1 per call. For cells of 1km radius on average such fast Mobiles will need 2 to 3 cell hops during a 1 min call. This would be about 10 times more frequent than the periodic updates we mentioned earlier. It makes sense to assume that whatever the mobiles do, the number of updates should not grow more than 10 times over the number of updates dictated by periodic updates.

There is one more aspect to cell size, namely power consumption. Most power in mobiles is consumed in sending or heavy processing. A location update will most likely wake up the main processor on the mobile, consuming power. Frequent location updates will deplete the mobiles battery quickly. From the point of view of power saving, the more the mobile can sleep the better. Cellular phone and network vendors have put a lot of effort in creating more

¹ In the calculus we assume that cell diameter = cell intersection on the path of the mobile for simplicity.

tricks that allow the mobile to sleep as much as possible. For cellular radios the need for power saving is a major design consideration. For example WLAN suffers from high power consumption.

The conclusion is that from the point of view of scaling the location update traffic onto a reasonable level, a true mobile system must have support for cells of one to several kilometers in diameter. This reasoning is aligned with what actually has happened in the past. During the 1990s GSM had several competitors such as CT2, DECT and PCN that provided small cells only. These systems were gradually pushed away from the market. (Fair enough, besides cell sizes there are many other good reasons why they failed). This reasoning also suggests that WLAN will have a hard time in trying to win over GSM and 3G as a wide area mobile solution.

GSM mobility solution for packet services

Background on IP networks

There are differences in requirements for mobility management in circuit and packet networks. Let us first give some background on IP networks that in practice are the target networks for packet services in GSM.

In IP networks, network service is connectionless and best effort. This means that the sender creates a packet with a destination address, hands it to the network and hopes that the network will be able to deliver it to the destination. There are no acknowledgements on IP level, so the network does not offer any assurance of delivery. Each packet is processed in the network nodes called routers independently of the next packet irrespective that they may belong to the same flow.

Routing in IP network is dynamic, i.e. based on dynamic routing protocols. The job of routing protocols is to create forwarding tables in the routers. A router reads the destination address in the current packet, *looks up the address in the forwarding table based on longest match*, finds a forwarding entry and directs the packet onto the outgoing port found in the forwarding entry.

When the status of links or routers in the global Internet changes, the change is noticed by or reported to the routing protocols. The routing protocols distribute the information about the change possibly applying policy rules and aggregation of information and each node that receives the info will calculate a new forwarding table.

Usually, hosts (a mobile station that connects to an IP network will become a host in the IP network) do not appear in forwarding tables. This would lead to very large tables and to a non-scalable need of updating host status information across the IP network. Instead, a routing entry is identified by an

IP address prefix of variable length. The IP –address of a host may be static or may be assigned upon establishing a network connection dynamically (using for example the DHCP protocol).

The core of the Internet (non-default routers) has routing tables that have a few hundred thousand entries. The size of the forwarding table is seen as a major problem at the moment. The larger the tables are, the more costly the core routers will become and the harder they will be to maintain. Stability of the core routing tables is another problem. For example when an important broadband fiber connection (or a set of connections on an underwater cable) recently broke because of an earthquake under Pacific, it took several days for the routing tables to stabilize.

The scalability of routing favors a mobility solution that assigns a new IP address to a moving mobile on cell change (or a change from a set of cells to another). Only if the IP addresses that mobiles have using a particular cell are aligned with the network topology, the routing will not be impacted by mobility.

TCP is used for most data transport over IP. It assumes that a session for which TCP tries to guarantee reliable delivery is identified by originating and destination IP-addresses and port numbers and the protocol (TCP in this case). It follows that the session breaks down if one of the parties in the session changes its IP address. From this point of view the solution that follows from routing scalability does not fly.

Mobile IP

Mobile IP solves the dilemma outlined in the previous section by introducing the Home Agent and the home address along with the Foreign Agent and the care-of-address. Corresponding nodes that wish to reach the mobile will do so using the home address. For actual communication the mobile uses the care-of-address. This leads to triangular routing and fails to hide mobility entirely from the global Internet. This solution was not available when the Packet Core was added to GSM.

GPRS solution for mobility

Instead of using Mobile IP, GPRS uses tunneling to hide mobility from the Internet. If we look how a single mobile connects to the Internet using GPRS, the packet core network is like a wire that attaches the mobile to the Internet. The “wire” is actually a tunnel over the transport IP network connecting BSS, SGSN and GGSN. When a mobile changes cell, the mobile may be assigned a new IP address but this is hidden from the TCP that is used as the transport protocol by the user application.

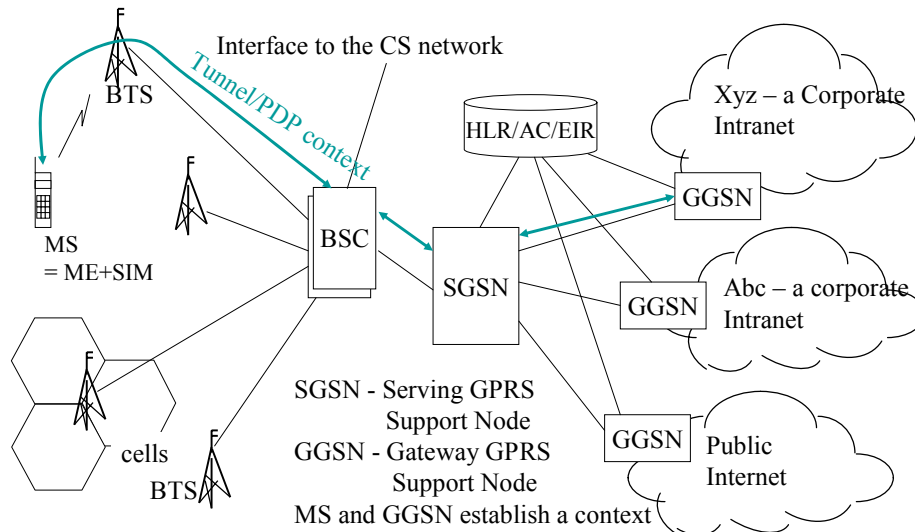

Figure 9.4: GPRS network.

IP data flows are much shorter than telephone calls. Therefore paging a packet services mobile from a large Location Area would make the solution inefficient (a lot of hassle for the sake of a few Kbytes). For this reason packet mobiles are tracked into smaller areas than the Location Area called the Routing Area (RA). Also an RA is a contiguous set of cells but a location area may have several routing areas.

Figure 9.4 shows the network elements used in GPRS and their connections. SGSN plays a similar role as the MSC/VLR. The tunnel called “PDP context” (PDP stands for Packet Data Protocol) is shown to connect a mobile to the Internet through several access and packet core network elements. HLR is used to grant or deny access to a particular packet data network behind a GGSN and to keep track of the location of the mobile with the accuracy of an SGSN.

GPRS mobility state model

Actually, the accuracy with which the network keeps track of the location of mobiles varies following the different activity levels of mobiles. Obviously, we can loosen the tracing for inactive mobiles saving energy and location update traffic. On the other hand, if a mobile is actively communicating, for better performance and user experience, the network should trace the mobile as accurately as possible. This is accomplished by the mobility management state model that resides both in the mobile and the SGSN for each mobile. The models have minor differences but let us ignore those and just show a generic model. The model is in Figure 9.5.

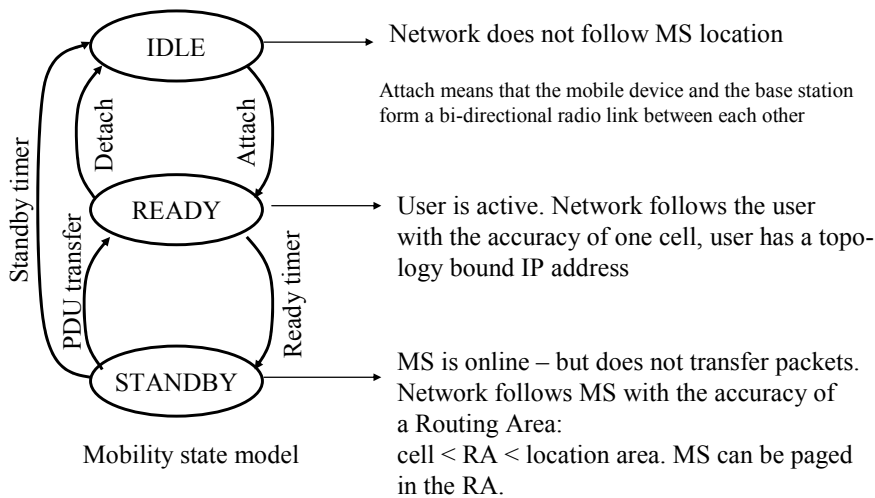

Figure 9.5: Mobility state model for packet terminals

Figure 9.6 shows how powering a GPRS MS will attach the MS to an SGSN creating the basis for mobility management of that device. Later, at any time when the MS wishes to use packet based services, it will activate a Packet Data Protocol Context (PDP Context). Only at this stage it acquires an IP address that it can use for global communication.

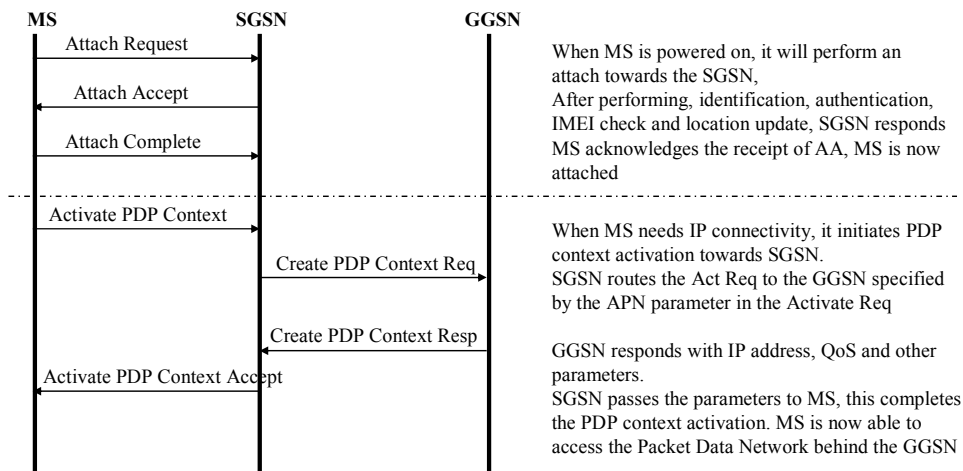

Figure 9.6: Attach and PDP context activation in GPRS

Summary of GPRS mobility solution

GSM has two mobility management solutions: one for circuit switched services and the other for packet switched services. We will see that this is reflected for example in MAP. The solutions are similar from the HLR point of view but there are difference in the data and models that actually implement the solutions.

The role of GGSN is to assign an IP address to the packet terminal such that it will not change during a TCP or other transport session. Several methods including DHCP are used to assign the IP address. The network of BSC/SGSN/GGSN uses its own internal “transport” IP network with its own internal topology bound IP addresses and its own DNS to hide mobility of terminal from the external IP network or the global Internet to which the terminal wishes to connect. The job of SGSN is to manage the tunnels called PDP context through that internal IP network from mobile packet terminals to the GGSN.

In the tunnel, there are two IP networks on top of each other: the transport IP network and the payload IP network. This leads to heavy protocol stacks and a lot of header information in GPRS originated and terminated packets. Therefore, with the rather slow speed of GPRS access the result is quite a lot of packet delay. A solution for reducing packet delay is header compression. We will discuss header compression later related to IP voice but not specifically for GPRS.

In the GPRS solution *pushing packets to GPRS terminals is an issue*. Besides being behind GGSN and the rest of the access and packet core elements, the mobiles are behind an operator firewall. Before an incoming packet can be delivered to an inactive but powered mobile a lot must happen. Somehow the firewall must be traversed, the GGSN must be located and assign an IP address to the mobile (actually the packet can not be formed in the first place if the destination does not have an IP address). Several solutions have been proposed but we will not discuss them in detail.

Introduction to MAP

Call setup in GSM and for circuit switched services in 3G is still based on ISUP like in ISDN. The purpose of MAP is to provide all the added signaling functionality required for mobility management in core networks and for several services that are part of the core GSM specification but are not included in ISDN. An example of such services is the short message service. It became part of GSM almost by accident. Short message are carried over signaling channels in the access and the SS7 networks. The transport protocol is MAP.

The lumping of all kinds of requirements on MAP has resulted in a specification of some 1000 pages for one version of MAP. New functionality has been added into MAP gradually first by ETSI and later by the 3GPP in progressive releases. Deployment of the new releases does not take place over night. Therefore, a MAP specialist will know several releases.

Looking at the history of ISDN and GSM and comparing the two systems, one can say that ISDN makes poor use of the fact that ISDN terminals are computers. For services implementation it relies on the network and tries to control carefully what the user can do with his or her terminal. GSM took a step towards recognizing that terminals are intelligent and will contain a lot of software. Terminal intelligence is important for managing mobility and short messaging make them to become more than phones. Consumer market economies of scale have served GSM well.

MAP development roadmap

MAP has developed through many phases and later releases. The early history is depicted in Figure 9.7.

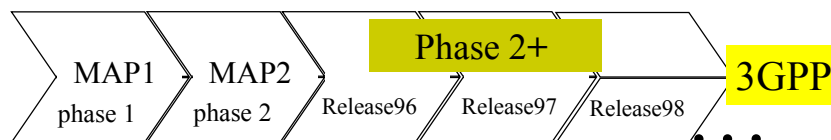

Figure 9.7: Early development history of MAP

The development started in ETSI but was moved to 3GPP, the 3G Partnership Project – that is a global industry forum late 1990's. GPRS was introduced in phase 2+. 3GPP has released new versions of MAP for its releases (Release 99, release 4, release 5, release 6 and 7).

MAP works between many network elements. The list has been growing during the development history. Table 9.2 lists the network elements that use MAP.

EIR	Equipment Identity Register - usually integrated with HLR
GCR	Group Call Register (does not appear in rel 7)
GGSN	Gateway GPRS Support Node - for interfacing to IP or other PD networks
GMLC	Gateway Mobile Location Center - for interfacing to Location Services
GMSC	Gateway MSC - for routing calls from visited network
gsmSCF	GSM Service Control Function - IN service control element
HLR	Home Location Register - the key database
MSC	Mobile services Switching Center
NPLR	Number Portability Location Center - for locating an HLR
SGSN	Serving GPRS Support Node - the "MSC/VLR" for PS services
SIWFS	Shared Interworking Function Server - for interfacing CS data services to IP or other PD networks (not in rel 7!)
SMS GWMSC	SMS Gateway MSC - for terminating SMS routing
SMS IWMSC	SMS Interworking MSC - for originating SMS routing
USSDC	USSD Center - part of gsmSCF
VBS/VGCS Anchor MSC	Voice broadcast/group call service Anchor MSC
VBS/VGCS Relay MSC	Voice broadcast/group call service relay MSC
VLR	Visitor Location Register -in practice integrated with MSC
VMSC	Visited MSC

Table 9.2: Network elements that use MAP.

MAP implements operations. Some of them appear only on interfaces between two particular network elements, some are more generic. Table 9.3 summarizes the operations found in release 98, the final one by ETSI.

if	Elements	Mobility Management	O&M	Call Handling	Supplementary Services	Short Messages	PDP Context	Location Services	Sum
B	MSC - VLR	14	2		13	3			32
C	GMSC - HLR			1		2			3
D	HLR - VLR	9	2	4	12	1			28
E	MSC - MSC	5		1					6
F	MSC - EIR	1							1
G	VLR - VLR	1							1
J	HLR - gsmSCF	1			3				4
L	MSC - gsmSCF				1				1
C	SMSGW - HLR					2			2
	MSC - SMSGW					2			2
	VBS/VGCS Anchor MSC - VBS/VGCS Relay MSC			4					4
I	VBS/VGCS aMSC - GCR	Vendor specific							0
K	vMSC - SIWFS			2					2
Gr	SGSN - HLR	6							6
Gc	GGSN - HLR						3		3
Gd	SGSN - SMSGW					2			2
Gf	SGSN - EIR	1							1
Gb	SGSN - BSS	Not discussed on this course - not a MAP interface							0
Gs	SGSN - MSC/VLR	optional - not a MAP interface							0
	GMSC - NPLR			1					1
Lh	GMLC - HLR							1	1
Lg	GMLC - MSC							2	2
	use cases	38	4	13	29	12	3	3	102

Table 9.3: MAP operations in release 98.

In Table 9.3, the operations are categorized into Mobility management, Supplementary Services, Call handling, Short messaging, O&M, PDP context and (Geographical) Location services.

More than one third falls under mobility management and just less than 80% fall under the three most popular categories: mobility management, supplementary services and short messaging. Broadly speaking, PDP context operations also relate to mobility management for packet terminals.

In this lecture we ignore the operations that take place between MSC and VLR because these two logical network elements are in practice always implemented in one system. We will also skip the O&M and geographical location services.

By Release 7 from 3GPP MAP has become leaner and cleaner supporting 81 services. This is possible because 3GPP counts on packet based cellular services in the future and has created the IP multimedia subsystem (IMS) sitting behind or on top of the Packet Core. IMS uses its own protocols for talking to the HSS that replaces HLR in the 3G architecture.

MAP services model

MAP works between MAP service users and MAP service providers. This is depicted in Figure 9.8.

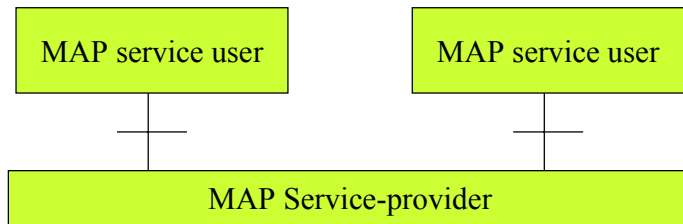

Figure 9.8: MAP Service Model.

The roles of service user and service provider are taken by network elements such as MSC or HLR dynamically. In one service an element can be a service user and in the next a service provider.

The environment of MAP

Let us take a look at the environment of MAP in a network and take look at MAP from underneath and above. HLR is the most important network element talking MAP. It contains a lot of data. Knowing something about the data is important for understanding MAP. We will take a look at the data as well.

Addressing in MAP

MAP makes use of several Subsystem Numbers (SSN) in SS7 and Global Title addressing provided by SCCP. This is demonstrated in Figure 9.9.

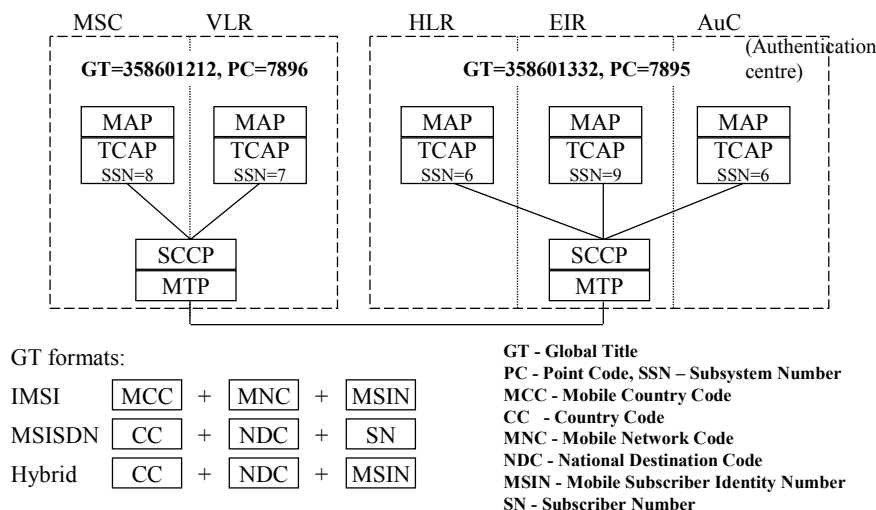

Figure 9.9: Addressing in MAP

MAP may use all GT formats using IMSI numbering, E.164 numbering (MSISDN) and the hybrid format as well. Different physical and logical network elements are identified using the SS7 subsystem number.

A view from above

The application using MAP for communication will use the MAP_OPEN service to open a dialogue with the remote element. The application will use the MAP_CLOSE service to close the dialogue. When the application decides that all components are in place for the actual communication, it uses the MAP_DELIMITER service.

Both the service user and the service provider can abort a MAP service by MAP_U_ABORT and MAP_P_ABORT service respectively. By MAP_NOTICE the MAP service provider can notify the user about something without affecting the state of the dialogue.

A view from underneath: MAP uses TCAP

MAP uses the structured dialogue service provided by TCAP. This is depicted in Figure 9.10.

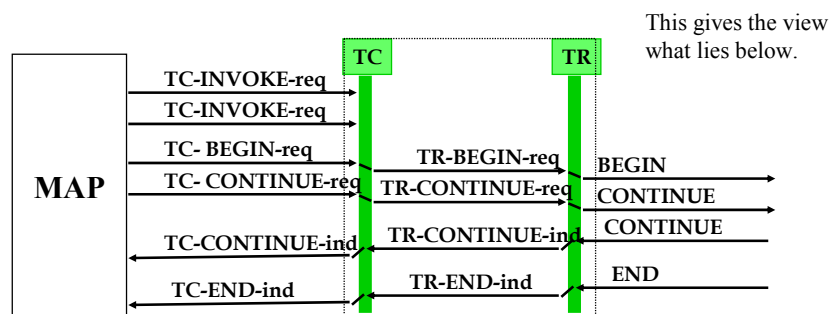

Figure 9.10: MAP use TCAP structured dialogue.

Data in HLR

HLR contains *subscriber information* including the subscriber's location addressable using IMSI found on the SIM card. HLR also contains all kinds of service information (which services the subscriber can use). This information is addressed using MSISDN. HLR maintains a mapping between IMSI and MSISDN and vice versa.

Release98 HLR database has

- location information (VLR number)
- basic telecommunications services subscription information
- service restrictions (e.g. roaming limitations)
- supplementary service parameters
- GPRS subscription data and routing information: e.g. APN – Access Point Name pointing to the PDN a user is allowed to connect to.

The Access Point Name (APN) is similar to an URL and one APN may point to the Internet or to a particular Intranet GPRS service connects the user to.

Mobility management support in MAP

Mobility management support in MAP can be classified into several categories. For example the classification can be:

- Location management
- Handover MSC-MS during a call
- Authentication and security
- Mobile terminal validation: IMEI - mobile equipment id queries
- Subscriber management
- Fault recovery (we skip this)

Note that handover need support on many levels for example in BSSAP. For cell to cell changes in a location area MAP does not need to get involved. On this course we will however skip BSSAP.

Location Management in MAP

Location management has operations for location updates for circuit switched services. The operations are depicted in Figure 9.11.

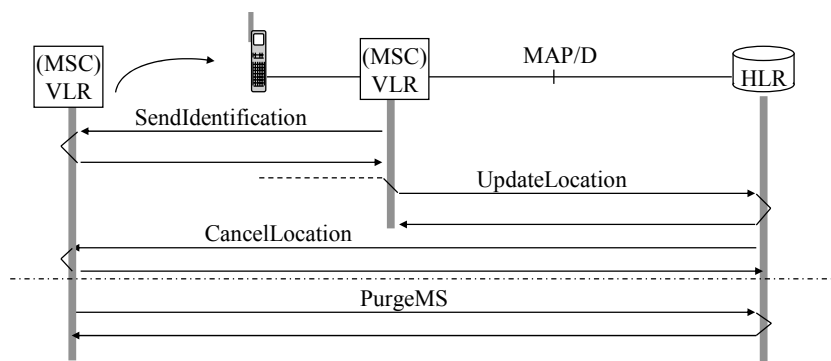

Figure 9.11: Location management for circuit switched services.

The **SendIdentification** operation is used by the new MSC/VLR that sees a new mobile in its area of responsibility to request information from the previous VLR about the user. Once the new VLR takes responsibility for the new mobile, it uses the **UpdateLocation** operation to tell about the change of responsibility to the HLR of that user. Both of these operations are confirmed. When HLR has been updated it can use the **CancelLocation** operation towards the old VLR to let it know that it can remove its record of the user from its database.

Independent of all above, it is possible that VLR loses track of a mobile it was responsible for. The mobile's battery may have gone flat, mobile was switched off or went out of coverage. After a while the VLR tells the HLR that it has no idea where the user is by using the **PurgeMS** operation and the VLR removes the data about this mobile.

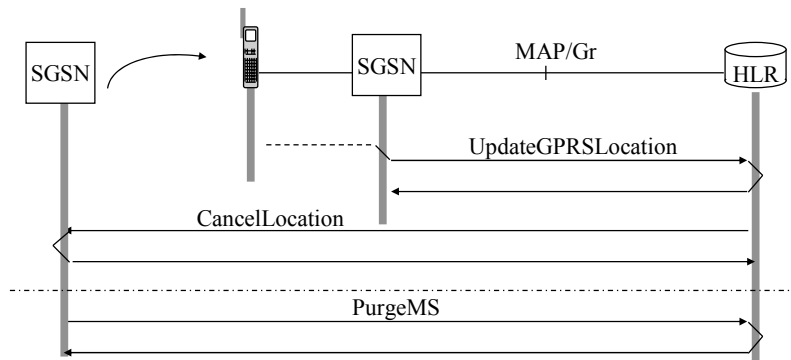

Figure 9.12: MAP operations for packet terminal location management

Location management for packet terminals takes place in a very similar manner as in Figure 9.10. However, separate operations are present in MAP for the purpose. These operations are depicted in Figure 9.12.

Similar to the circuit switched case, **SendIdentification** operation is used to request information about the MS from the previous SGSN. The operation, **UpdateGPRSLocation**, stores the new location (new SGSN) to the HLR. **CancelLocation** is used to remove stale data from the previous SGSN. Like before, **PurgeMS** is independent of the rest and is used by a SGSN that has lost track of a mobile to update the status change in the mobile’s HLR.

Location of user in Mobile Terminated call

We already talked about the original variant of locating the user for MT calls. Figure 9.13 shows the location of Mobile for a terminated call in case when Number Portability is supported between several Mobile Networks.

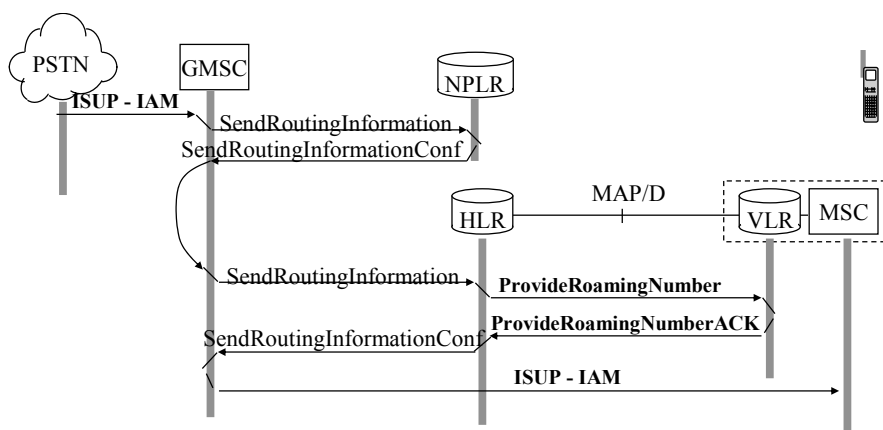

Figure 9.13: Locating a Mobile for a terminated call.

The originating or a transit network will route the call to a Gateway MSC using the directory number from dialing. The GMSC may of course use IN for translating the MSISDN number to an operator specific number. We show how NP can be supported directly with MAP. The GMSC uses the same operation that it would without NP use to request HLR about the location of the MS i.e. **SendRoutingInformation** for sending a query to a Number Portability Location Register (NPLR) that will return enough digits for routing the further query to the right HLR. The GMSC uses the same **SendRoutingInformation** operation to the HLR of the user. The VLR may have earlier allocated an MSRN to the Mobile and given it to the HLR for the duration of the visit. If not, the HLR will use the **ProvideRoutingNumber** operation addressing a query to the VLR. The VLR will return to the HLR the MSRN in **ProvideRoutingNumberAck**. Now, the HLR will confirm the earlier **SendRoutingInformation** operation and hand the MSRN to the GMSC. Having received the MSRN, GMSC is ready to use ISUP for outgoing signaling towards the visited MSC. The GMSC will use the regular IAM message to continue call setup towards the callee.

Triangular routing in GSM

Let us take a look at a call case where the MO and MT subscribers reside in a foreign network: for example two friends who are Elisa customers are visiting Australia. Making calls directly in the visited network with the necessary routing information queries to HLR in Elisa's network would be the efficient thing to do.

There is a problem of trust in this scenario. After the visit to Australia, the visited network operator may send a significant bill to Elisa and Elisa will charge it to its customers without really knowing whether the calls were really made. Due to this trust problem such calls are usually routed quite inefficiently through the home network. To remove such triangular routing there is even a **ResumeCallHandling** operation in MAP between an MSC and the Gateway MSC but this operation is rarely used.

Handover from one MSC to another MSC

We skip lower level handovers between two cells, between two BTSs and between two BSCs. Because the topic is MAP we will take a look at MAP support to handovers between two MSCs.

A handover is needed when one of the mobiles is engaged in a call and moves from the area managed by one MSC to the area of another MSC. The situation is depicted in Figure 9.14.

First of all, the principle of the MSC to MSC handover is that the original MSC always remains on the call path and becomes a so called anchor MSC for

the call. The anchor MSC is marked as MSC-A in the Figure. The new MSC is marked as MSC-B.

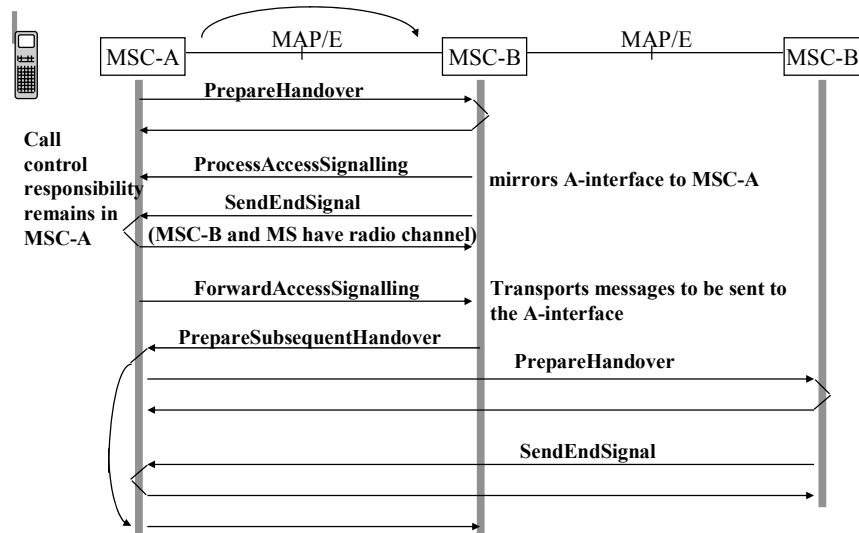

Figure 9.14: MAP support for MSC to MSC handover.

The handover starts when the anchor MSC sends the **PrepareHandover** operation to the new MSC. The anchor MSC has learned the identity of the new MSC from the MS that has to have two active signaling channels to cells connected to the two MSCs for a while. The new MSC starts mirroring the events of its access side interface towards the MS to the anchor MSC by sending the **ProcessAccessSignalling** operation. Using this operation MAP becomes the transport protocol for access signaling! When the new MSC is happy about the quality of its connection with the MS it will use the **SendEndSignal** operation to let the anchor (or the previous MSC) know that it may release the radio access resources that were previously used by the MS. This is a confirmed operation.

When call control in the anchor MSC creates a message to be sent to the MS, it uses MAP as the transport protocol with **ForwardAccessSignaling** operation to the new MSC that has a radio link to the MS. If MSC-B's connection is getting weaker and the MS initiates a handover to MSC-B', MSC-B will let the anchor MSC know about this by **PrepareSubsequentHandover** operation. The rest of the subsequent handover takes place between MSC-B' and the anchor MSC similarly to the previous handover between MSC-B and the anchor MSC. The SendEndSignal operation needs to be routed to the previous MSC-B. The anchor MSC finalizes the operation by sending the confirmation of the PrepareSubsequentHandover to the previous MSC-B.

Security operations in MAP

The purpose of security operations is three-fold. First they ensure that only authorized users that can be billed are given service. Second, mobility itself does not make sense without authentication – otherwise anyone could impersonate anyone else and lie about the location of that user.

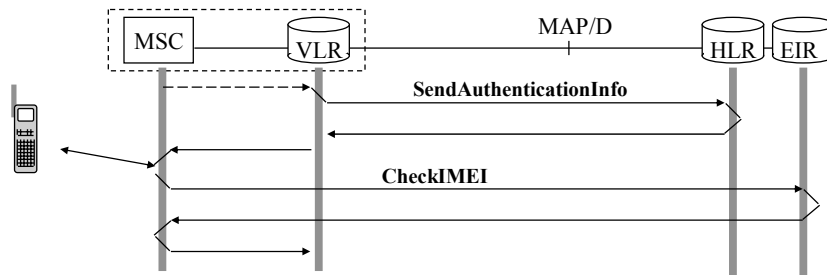

Figure 9.15 Security operations for circuit switched services

The service could hardly be trusted by anyone. Third aspect is that Mobile Terminals have an identity on silicon that is difficult to change. The network is able to check this identity in order to track stolen MSs and remove them from the network. The two operations in this category are depicted in Figure 9.15.

The **SendAuthenticationInfo** operation is between the VLR and the HLR (AC). In actual use it will be interleaved for example with location management operations. Such interleaving is for the application using MAP.

The **CheckIMEI** operation is sent by the VLR to the EIR. EIR will check the Equipment Identity against the blacklisted and grey listed phones. There is a global register that is distributed off-line among all GSM operators.

Similarly as the MSC/VLR uses the above operations to authenticate the user and to validate the user's equipment, SGSN can use the same operations for packet switched services.

Subscriber management operations

MAP supports Subscriber management operations for synchronizing the information between VLR and HLR. The operations are depicted in Figure 9.16.

With the operations **InsertSubscriberData** and **DeleteSubscriberData** all information about a subscriber residing in the VLR, can be manipulated by the HLR that has the master copy of the information. HLR does not store detailed location information and that information is only needed by the MSC/VLR and thus does not need to be synchronized.

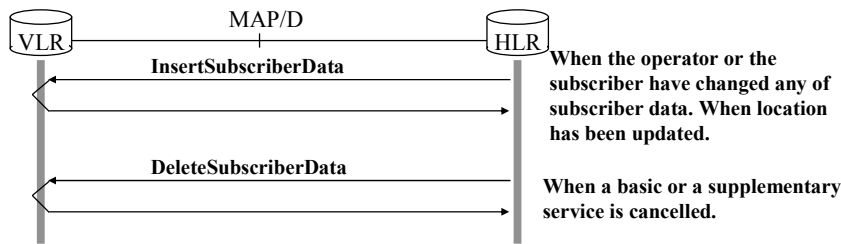

Figure 9.16: Subscriber management operations

There are 3 types of MS: (a) mobiles for simultaneous CS + PS services, (b) mobiles for alternate CS/PS services and (c) GPRS only. Type b has two modes. For MSs of types (b) and (c) the above operations are used to store subscriber data in SGSN and delete the data from SGSN.

Network requested PDP context activation

When someone tries to reach a GPRS mobile it may be necessary to activate a new PDP context for the target mobile.

To achieve this, a GGSN may use the **SendRoutingInfoforGPRS** operation to HLR to get an address for the SGSN. After that pushing packets to the mobile becomes possible (this leaves it open how the MS gets its IP address and how that address is delivered to the originator of the communication).

Having learned about an active GPRS terminal HLR may also use the **NoteMSPresentforGPRS** operation to GGSN to let the GGSN know that the terminal is available for packet services.

Supplementary services operations in MAP

Most supplementary operations are passed from MS via MSC/VLR to HLR for the purpose of manipulating the supplementary service information. The operations are listed in Table 9.4.

RegisterSS	Activation of call forwarding
EraseSS	Switching off supplementary services
ActivateSS	Activation of call blocking
DeactivateSS	Deactivation of supplementary services
InterrogateSS	Interrogation of supplementary service settings
RegisterPassword	Password setting for SS
GetPassword	Password query to MS
USSD operations	Unstructured SS data transport

Table 9.4: Supplementary services operations in MAP.

The operations follow a *supplementary services life cycle model*. The idea of the life cycle model is that the subscriber may subscribe to a supplementary service, register data for the service himself, a specific operation is provided for registering a password for the service, next the user may activate the use of the service, deactivate the service and finally erase the data of the service. In addition, the subscriber may interrogate the settings of the supplementary service.

In the opposite direction there is an operation by which HLR can query the user for a password (**GetPassword**). Moreover, there is a generic operation for transporting supplementary services data in both directions. The service is called Unstructured Supplementary Service data (USSD) transport.

Short Message service support in MAP

Short messaging is a *store and forward* service. Messages are stored on a server on their way to the destination. It differs from e-mail because SMSs are pushed to the destination MS while e-mails are retrieved by the client program from a server.

Short message service was first defined for the GSM system. The designers did not have much faith in it especially in the role of a means of text messaging between users. However, the users had other ideas. Under many circumstances SMS is the fastest and most efficient means of communication. On average short messages are read within 30 min while e-mails are read within 48h (says Wikipedia). Later short messaging has been taken as a feature for many other systems besides GSM. At the moment globally short messaging is a billion dollar industry and a very nice money maker for the operators.

Short message architecture has three network elements. These elements are depicted in Figure 9.17.

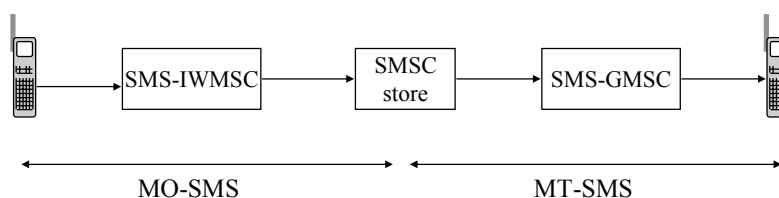

Figure 9.17 Short message service network elements.

Short Message service can be broken down into Mobile Originated (MO) and Mobile Terminated (MT) short message service. The element linking the two is called Short Message Service Centre (SMSC). MO short messages are routed to a Short Message Service Interworking MSC using MAP that has a

vendor specific interface to an SMSC. The delivery of short messages to the recipient takes place using the MT service. The SMSC hands a short message to a SMS Gateway MSC. This Gateway MSC makes the same kind of query to HLR like the GMSC for circuit switched calls.

Often the functions of IWMSC and GMSC are combined for SMS service. Then the node is called SMS Gateway (SMS-GW).

Short Message protocol stack

The short message transport protocol stack is depicted in Figure 9.18.

One of the parties in short message communication is an MS. The other party can be a Short Message Entity (SME) that may reside in a PC or be part of some service program on a server. The Short Message Link Protocol (SM-LP) is the SS7 protocol stack including TCAP/SCCP. A few operations in MAP form the Short Message Relay Protocol (SM-RP). One can also take the end-to-end aspects of Short message transfer and speak about the Short Message Transfer Protocol (SM-TP) between an SME and an MS or between two MS. The short message application protocol (SM-AP) completes the stack. SMS messages can be chained. Chaining makes use of a short header that is carried in the payload and processed at endpoints. Besides text messaging between users, SMSs can be used for premium services such as tele-voting and over the air programming of service configuration parameters in mobiles.

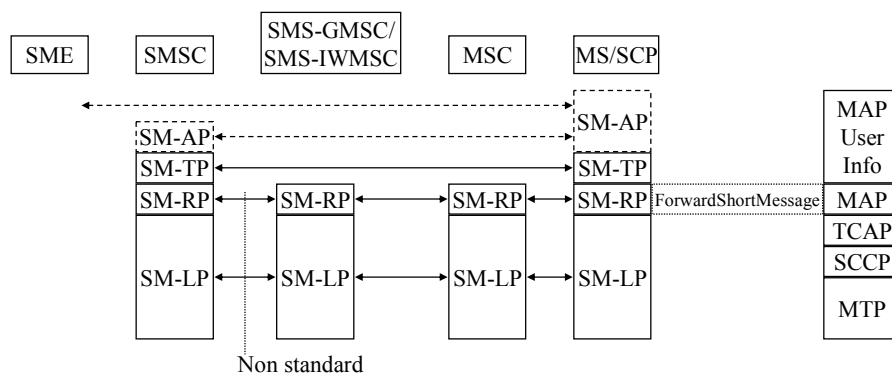

Figure 9.18: Short message protocol stack.

For a long time SMS routing could not be managed by services similar to call forwarding. Recently, in CAMEL v3 and v4, this routing control has been created.

The DTAP (Data transfer Application Part that is part of BSSAP delivers the SMS from the MS to MSC, alternatively MS can use the GPRS service to send the SMS first to an SGSN. Both SGSN and MSC use MAP to transfer the SMS to the Interworking MSC. For this purpose MAP supports the confirmed

ForwardShortMessage operation. The SMS IWMSC uses a vendor specific interface to transfer the message to the SMS Centre.

The MO service makes use of a routable telephone number of the IW MSC configured in the MS both on MAP and SCCP levels. The MSISDN number of the sender and destination are carried in the MAP protocol.

MO SMS service

The MO SMS service is depicted in Figure 9.19.

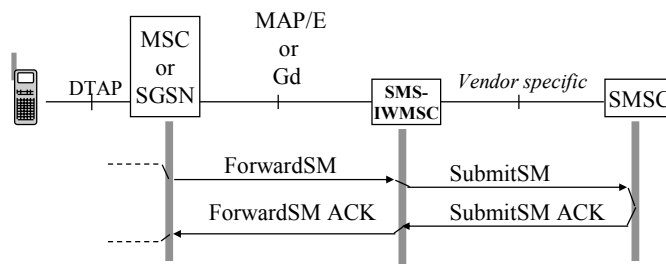

Figure 9.19: MO SMS service.

MT SMS Service

The MT SMS service is depicted in Figure 9.20. When the SMS centre delivers an SMS to the Gateway MSC, the GMSC will use the MAP operation, **SendRoutingInfoForSM**, to retrieve a routing number for the destination mobile. This is similar to what is done in case of circuit switched calls.

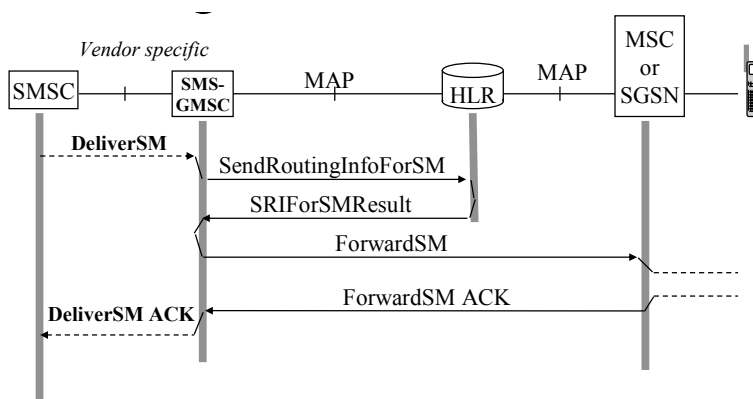

Figure 9.20: MT SMS service routing.

The GMSC also gets the IMSI of the destination user from the HLR. With the routable number the GMSC can formulate a **ForwardSM** MAP operation for the transfer of the SMS either to the visited MSC or the visited SGSN. In the latter case, the GPRS service is used for message delivery instead of using the signalling channels like in the original GSM system. In the ForwardSM operation the routable number of the visited node or MSC is used on SCCP

level while the destination on the MAP level is the IMSI of the target user. Also, the originating numbers of user A (MSISDN) and the SMS Centre are carried on MAP level.

Role of HLR in SMS service

The MAP operations for managing the status of SMS delivery are depicted in Figure 9.21.

The MS will report its reception status to MSC/VLR or SGSN that will use the **ReadyForSM** operation to deliver the information to the user's HLR. The specification originally required that an MS must be able to receive 5 SMS messages and if its buffer is full, it can tell its status to the HLR and the incoming messages are stored until better times. Also, it is natural that a mobile may become unreachable at any time. HLR keeps track of all such status changes of each mobile for the purpose of orchestrating SMS delivery.

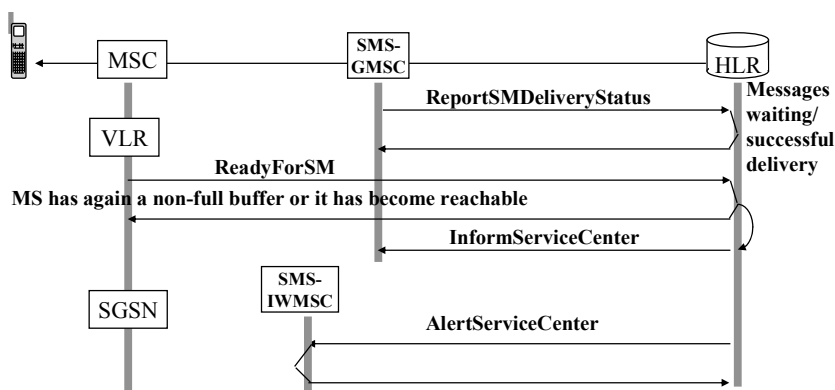

Figure 9.21: The role of HLR in SMS service.

The SMS Centres, through their Gateway MSC report to HLR that they have messages to a particular MSISDN. HLR organizes a waiting list of such SMS Centres.

When the HLR sees that an MS (MSISDN) is ready to receive short messages and that there are SMS Centres on the waiting list ready to deliver them, it will use the **InformServiceCenter** or the **AlertServiceCenter** operations to let the SMS Centre to know that it should deliver the messages. (The difference between the two operations is a bit obscure in the specs).

Other MAP services

Call Completion to Busy Subscriber

Call Completion to a Busy Subscriber is a service that has long haunted the signalling specification people.

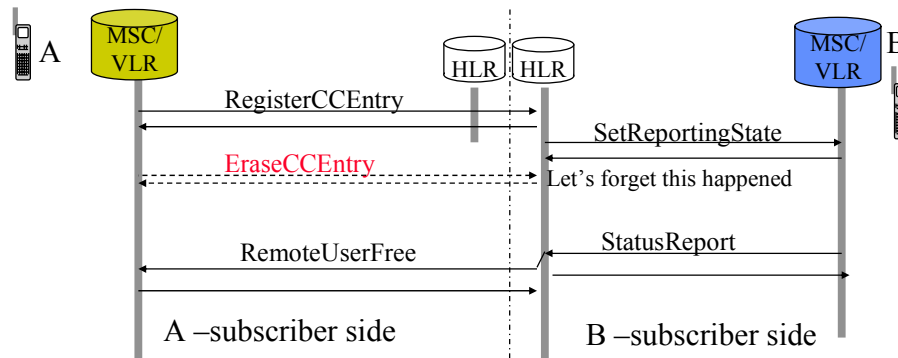

Figure 9.22: CCBS service support in MAP.

It has been used in the argument in favour of signalling that is not tied to voice circuits. For this aspect of architectural novelty, we will present the support of CCBS in MAP. The MAP operations that are needed by this supplementary service are depicted in Figure 9.22.

The caller A notices that the callee B is busy and activates the CCBS service. The visited MSC uses the **RegisterCCEntry** MAP operation to initiate status monitoring for B in the callee's HLR. Naturally, caller A can always cancel the CCBS service. For this purpose the visited MSC uses the **EraseCCEntry** operation to the callee's HLR. The callee's HLR will need to set the status monitoring in the visited MSC of the callee. HLR uses the **SetReportingState** MAP operation to request the vMSC to tell it when callee becomes free.

We will later see that the SIP protocol has generalized this mechanism for numerous service use cases. In SIP the operations are called **publish** and **subscribe**.

The vMSC uses the **StatusReport** MAP operation to tell the HLR that the user has become free. The HLR delivers this information to the originating vMSC using the **RemoteUserFree** MAP operation. Now, call established can be initiated by the caller's vMSC by alerting the caller and using ISUP to establish a call towards the callee B. Call charging will be normal, i.e. the caller will pay. (Naturally, we could have just stored the reporting state in callee's vMSC and established the call in the opposite direction but this would lead to B paying for the call which is unacceptable).

Unstructured Supplementary Service Data

Figure 9.23 shows the MAP operations for Unstructured Supplementary Service Data (USSD) transport. This is another bearer service making use of the SS7 signalling channels and facilitates a slow data channel between an MS and a server in the network.

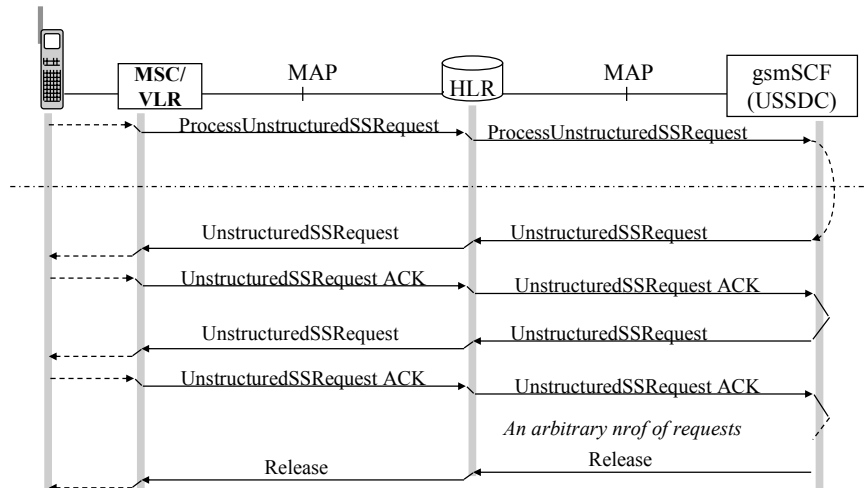

Figure 9.23: USSD operations in MAP.

The service can be used in the pull mode, i.e. MS initiates the data transfer or in the push mode where the server initiates the data transfer. When discussing IP networks we will see the difficulties related to push services. USSD using signalling channels that are always-on is one solution how push services to mobiles can be implemented.