

ISDN User Part - ISUP

- ✓ **ISUP - ISDN User Part**
 - › ISUP/TUP brief comparison
 - › ISUP additional features
- ✓ **Interworking of signaling systems**

ISUP is an international and national network signaling system for

- *call setup,*
- *supervision and*
- *release.*

*In addition it supports a wide range of ISDN supplementary services.
Used also in GSM and 3G.*

Separate versions for

- *International ISUP*
- *National ISUP in many countries (carry some legacy of older systems)*

Summary of course scope

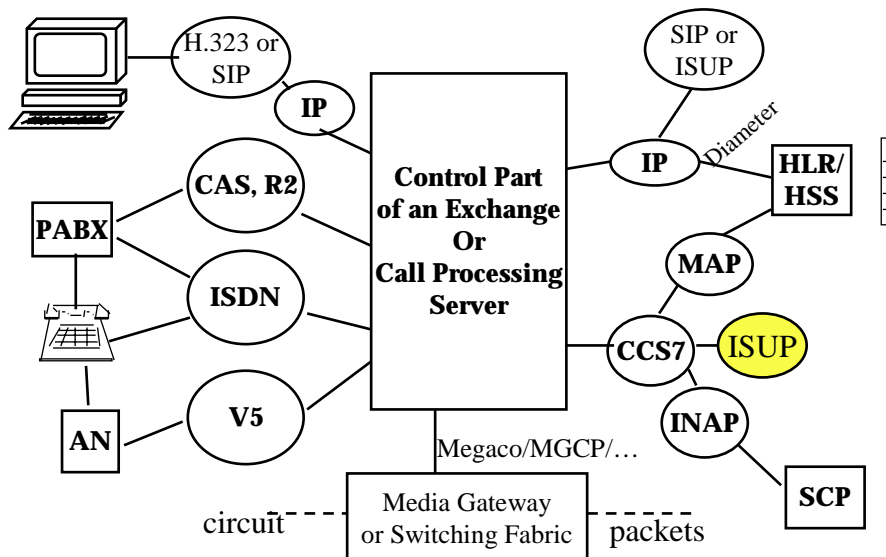

ISUP - ISDN User Part milestones

- TUP was specified before DSS1 ISDN user signaling during 1980's.
- ISUP2 specification was released after DSS 1.
- ISUP2 deployment in Finland started 1994.
- Core Network development path is CAS -> TUP ->ISUP.
- If TUP is already deployed, changing to ISUP is relatively easy by a software upgrade in exchanges, because MTP-infra is already in place.
- Recent development in ISUP:
 - ETSI additions of charging information messages into ISUP.
 - IETF (SIGTRAN) is specifying ISUP over IP

Why does ISDN need ISUP instead of TUP?

Limitations of TUP compared to ISUP:



DSS 1 terminal compatibility information can not be transported in TUP,



User-to-User information is not specified in TUP signaling messages



ISDN Suspend/Resume is not supported in TUP,



TUP does not support all (Euro-)ISDN supplementary services
- call waiting, call hold ...



In TUP release is non-symmetric / in ISDN it is symmetric

Bearer services supported by ISUP are

- ✓ speech
- ✓ 64 kbit/s unrestricted (= transparent 64kbit/s)
- ✓ 3.1 and 7 kHz audio
- ✓ alternate speech / 64 kbit/s unrestricted
- ✓ alternate 64 kbit/s unrestricted / speech
- 2 x 64 kbit/s unrestricted
- 384 kbit/s unrestricted
- 1536 kbit/s unrestricted
- 1920 kbit/s unrestricted

ISUP offers extensions compared to TUP, but CSN is not able to compete with packet switching (the Internet) in the long run!

ISDN basic structures

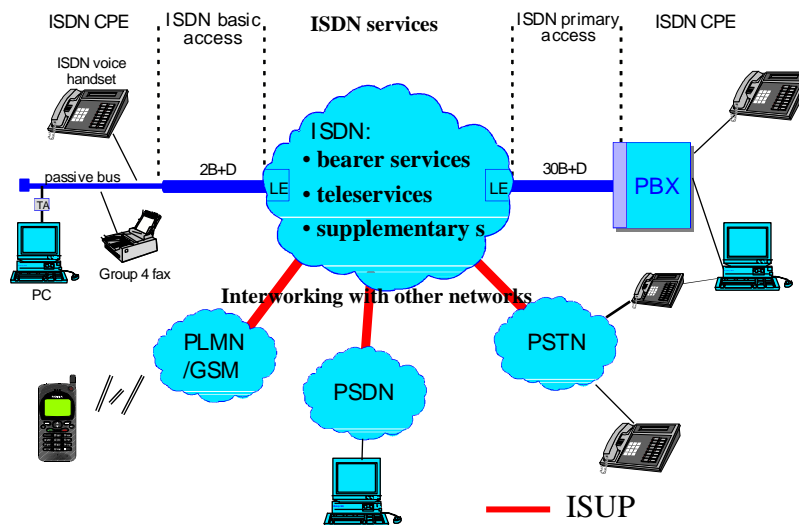

Basic structure of an ISUP message

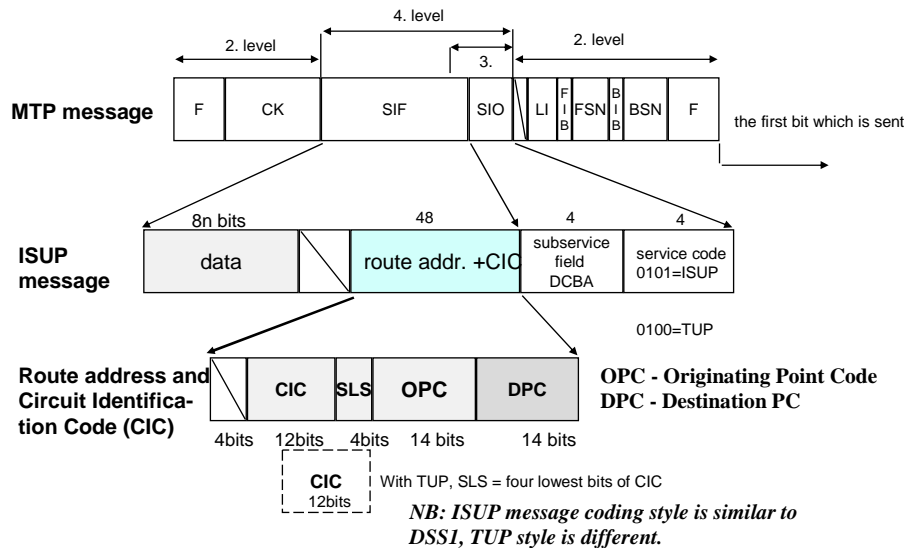

Call identification is based on a compulsory CIC and an optional (logical) call reference

- ✓ Call reference is recommended only for national use.
- ✓ $n \times 64\text{kb/s}$ connections are always built using consecutive timeslots, thus one CIC is enough.
 - › $n \times 64\text{kb/s}$ -connection is identified using the smallest CIC among the time-slots.
- ✓ CIC binds the user information channel (voice or data) and signaling together. One can not exist without the other
 - › --> one result is that in IN a special standardised Basic Call State Model is needed. The BCSM is used to track the state of the resources in an SSP (service switching point) while an SCP (service control point) processes additional features.
 - › Binding to CIC is also an issue when Interworking with IP Telephony systems because in IP telephony willingness to participate is established prior to any voice path activity.

A successful ISUP call (calling subscriber initiates release)

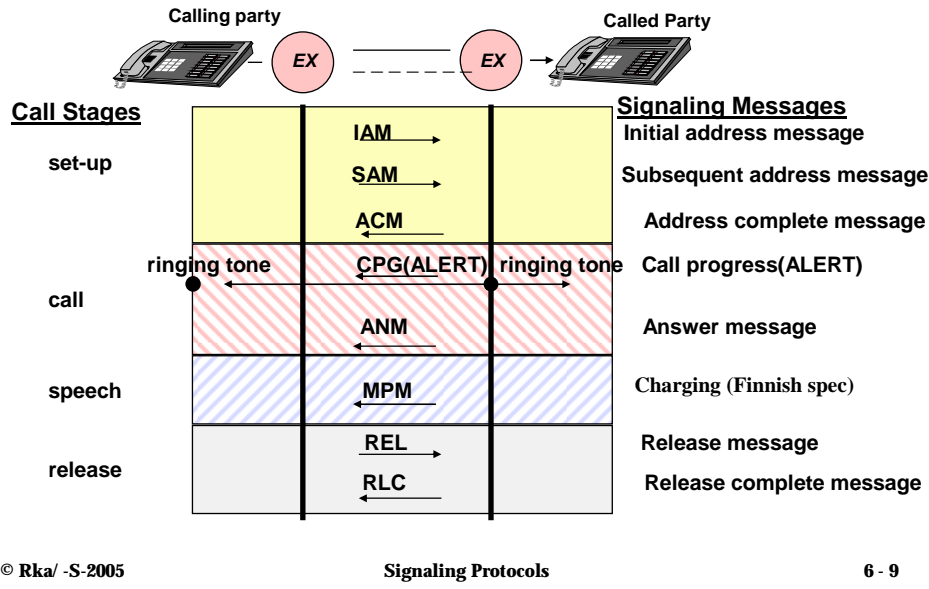

Sample ISUP messages

- ✓ IAM: will carry bearer service identification, all digits if dialling sequence is like in GSM, may carry some leading digits in case of PSTN like dialling sequence.
- ✓ SAM: sending of SAMs is dependent whether dialling plan has a fixed nrof digits for the leading digits sent in IAM (or that generated the IAM) or the dialling plan allows variable nrof digit per destination. Variable length numbers go hand in hand with DDI (direct dialling in for PABXs). Routing files may have instructions when to send SAMs and what kind
- ✓ ACM tells that no more digits are needed nor will be processed
- ✓ ANM tells that B-party has answered and charging can begin.
- ✓ Tariff information can be carried in Charging messages. Eases tariff maintenance and supports a more dynamic market place with competition between providers.

ISUP circuit supervision messages --> circuits and 2M connections can be taken into use and from use in a managed way.

- RSC Reset circuit
- BLO Blocking
- BLA Blocking acknowledgement
- UBL Unblocking
- UBA Unblocking acknowledgement

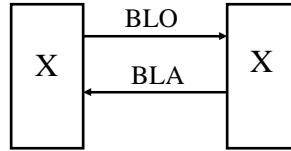

Can not place calls on cic def in BLO

- EHL End-of-hold (*)
- EHA End-of-hold acknowledgement (*)
- OLM Overload (*)
- UCIC Unequipped circuit identification code (*)

(*) For national use

Forward COMPATIBILITY is ensured from the 1992 release onwards

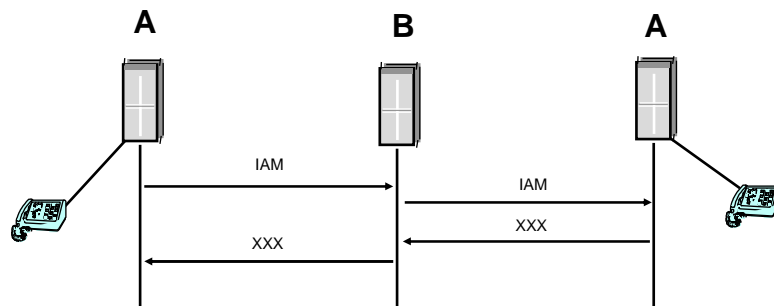

MESSAGE COMPATIBILITY INFO
 - TRANSIT AT INTERMEDIATE EXCHANGE INDICATOR,
 - RELEASE CALL INDICATOR,
 - SEND NOTIFICATION INDICATOR (CONF),
 - DISCARD MESSAGE INDICATOR,
 - PASS ON NOT POSSIBLE INDICATOR,
 -...

A message carries a rule what to do if something unknown=new in the msg

ISUP message coding supports ISUP software upgrades - old and new version can talk to each other!

Version compatibility rules: the following should not be changed:

- ✓ Protocol procedures, messages, information elements, coding, except to correct an error in the protocol.
 - ✓ Semantics of existing info elements.
 - ✓ Formatting and coding rules
 - ✓ Adding new parameters into mandatory part of Messages, Optional part can be extended.
 - ✓ Order of information items in an Information Element of variable length, new items can be added to the end of the IE.
 - ✓ Information item value =“all 0” == non-significant value.
- + **Fall-back and other compatibility procedures.**

Rules apply from ISUP'92.

Calling Line Identification Presentation - CLIP - is a supplementary service supported by ISUP

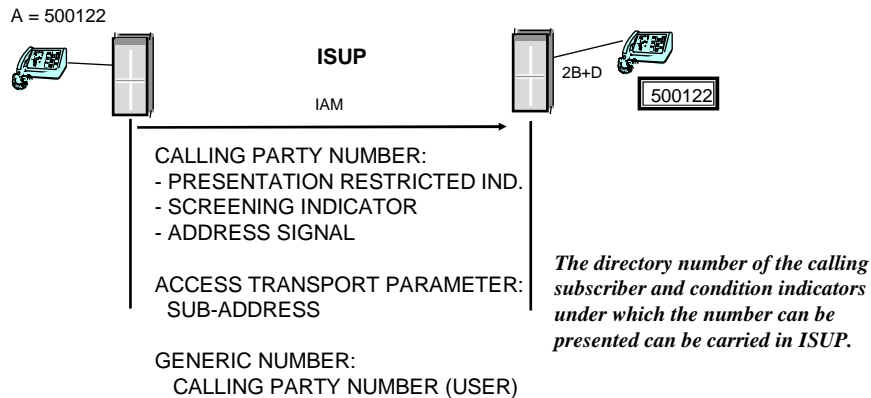

Calling Line Identification Presentation Restriction - CLIR - is a pair to CLIP

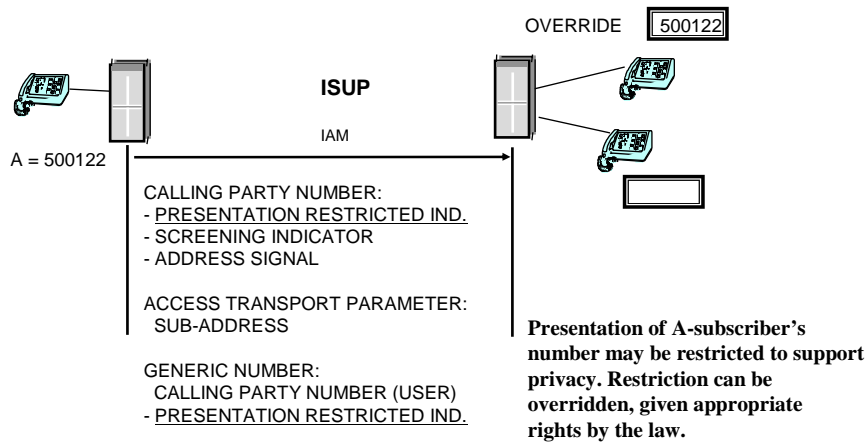

Connected Line Identification Presentation -COLP - is a mirror image to CLIP

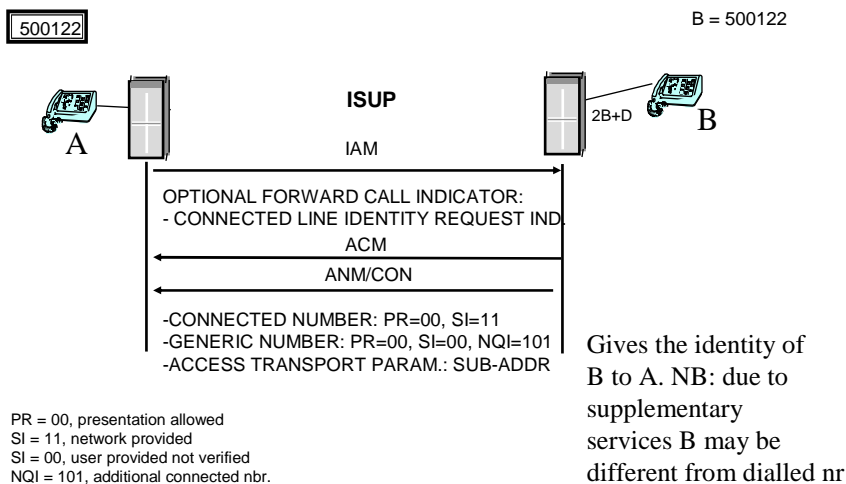

Connected Line Identification Presentation Restriction - COLR - is the pair to COLP

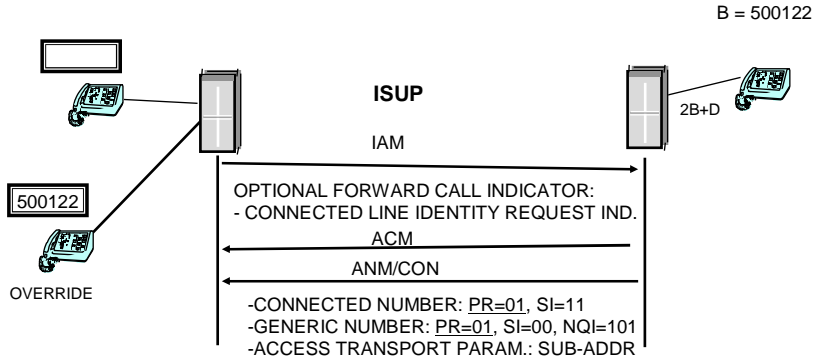

PR = 01, presentation restricted
 SI = 11, network provided
 SI = 00, user provided not verified
 NQI = 101, additional connected nbr.

User to User Signalling 1 - UUS1 - allows transporting user provided information over CCS7 network

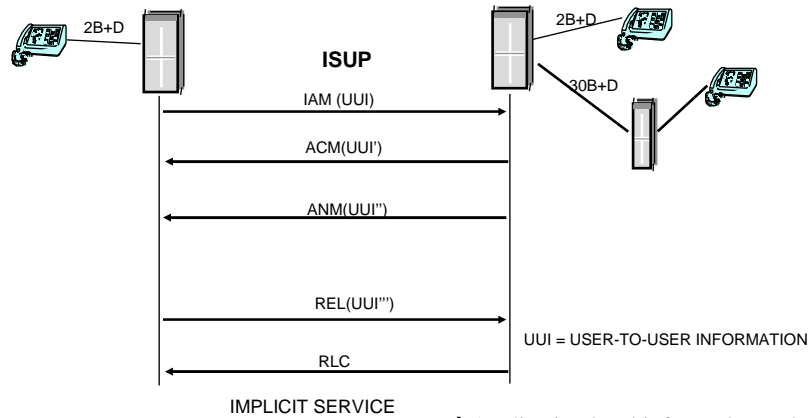

→ Application level info can be made a precondition of setting up a call.

Terminal Portability (TP) - ISDN allows interrupting a call and resuming it even from a different phone or phone line..

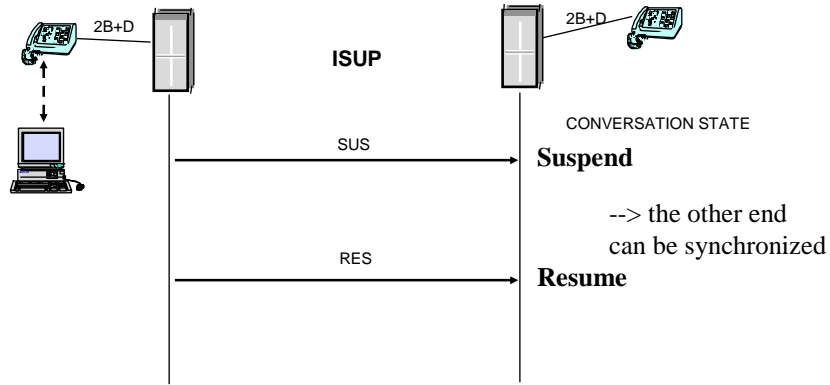

Call Forwarding No Reply - CFNR - automatically forwards an incoming call to C-number

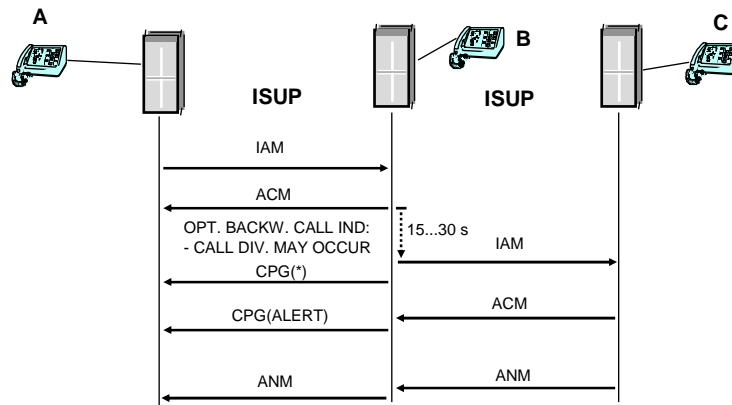

(*) CALL DIV. INFO, REDIR. NBR., GENERIC NOTIF.

Call from B to C is paid by B.

About supplementary services

- ✓ **Can be divided into A subscriber services and B subscriber services.**
 - › service data and control reside either at A or B
 - › not all supplementary services require support from network signaling
 - › some services can be implemented either in the terminal or in the network
- ✓ **Other examples**
 - › Call transfer
 - › Call completion to busy subscriber (call back when free)
 - › Call forwarding unconditional,
 - › Call forwarding on busy
 - › Many PABX –type services: call pick-up ...
- ✓ **Business wise: how important are these supplementary services? (very important when buying decisions are made but not widely used by subscribers...)**

Signaling interworking occurs in an exchange if two legs of the call are managed using different signaling systems

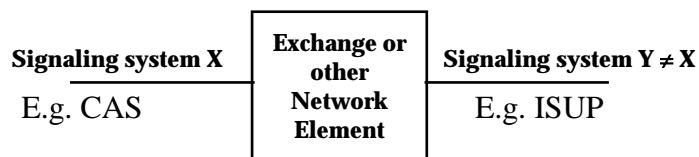

- ✓ **Interworking of signaling systems**
- ✓ **Also we talk about signaling interworking if two peer exchanges are manufactured by different vendors (interworking of different implementations)**
- ✓ **≠ compatibility**

DSS1 / ISUP -interworking

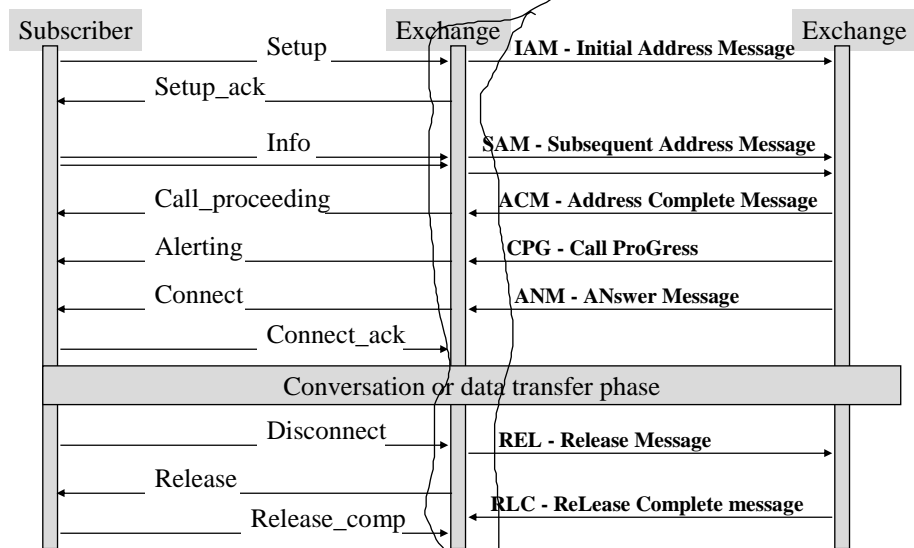

© Rka/ -S-2005

Signaling Protocols

6 - 23

Each signaling system has its own set of signals of information elements -> in interworking almost always some info is lost.

- To ensure smooth interworking, functioning need to be carefully specified. If we have n signaling systems, there are n^2 interworking cases!
- Standardization bodies use two methods for the specification of interworking:
 - *For Channel Associated signaling: event based FITE/BITE -method.*
 - *For message based signaling: layer oriented method.*

© Rka/ -S-2005

Signaling Protocols

6 - 24

Event based interworking specification method

FITE - Forward Interworking Telephone Event
 BITE - Backward Interworking Telephone Event } Between signaling systems.
 SPITE - Switching Processing Interface Telephone Event - internal to an exchange.

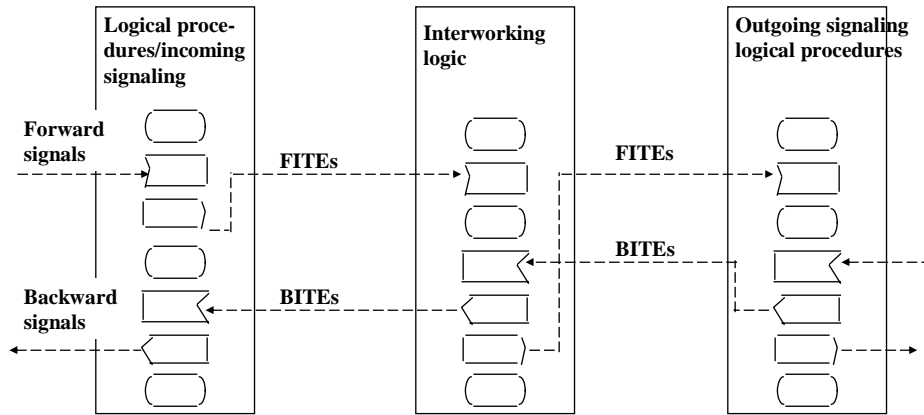

Incoming and outgoing signaling systems are analyzed only to the extent necessary for the specification of interworking. Logic is given using SDL.

Layer oriented interworking specification

Primitives carry the information between layers

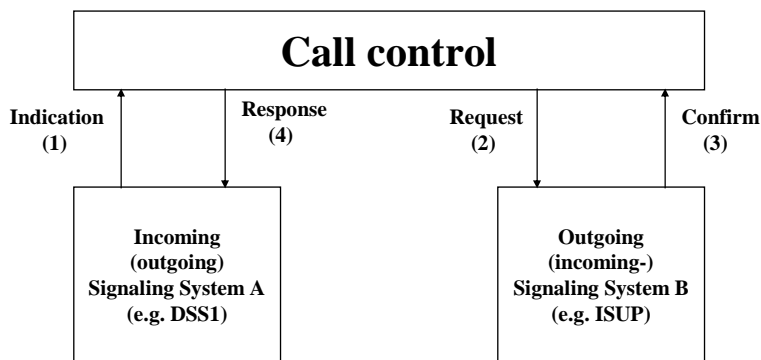

Numbers show the order of events

Mapping from specifications to implementation: case DX 200

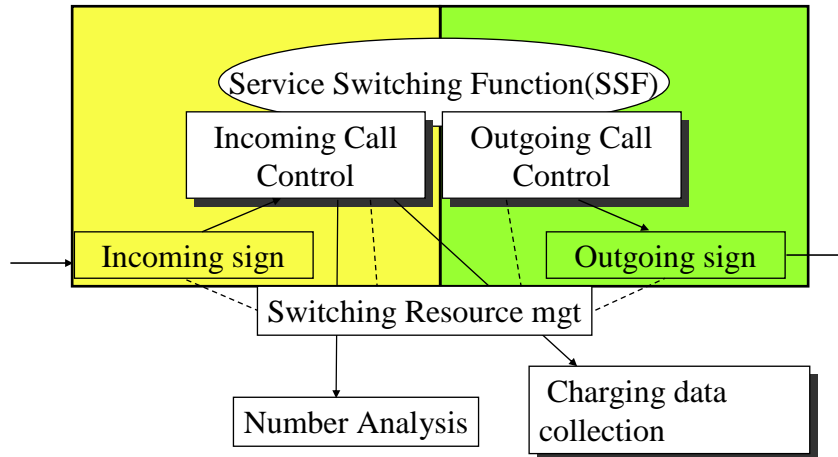

Signaling flow is described in more detail:

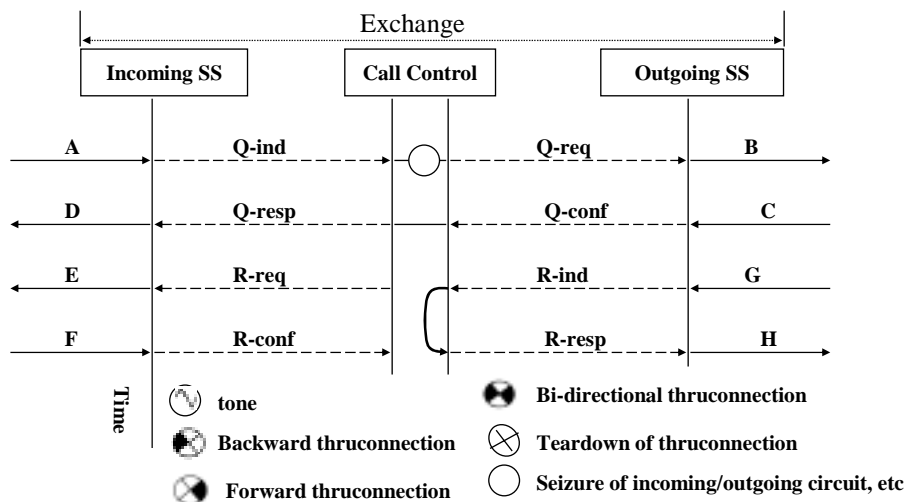

Latest development of ISUP

1. ISDN charging protocol to transport tariff and billing info
 - The Finnish network has traditionally carried charging messages. In most other countries the originating exchange needs to know all tariffs in the world.
 - Reflects the difference between monopoly and competitive markets
 - ETSI specifies messages between **charging points** to transport information about additional tariffs on a call by call basis:
 - Final tariff may be composed of many parts
 - tariff info is maintained by the party, who wants to earn the money.
 - Makes easier to apply dynamic tariffs.

ISUP2 carries charging info

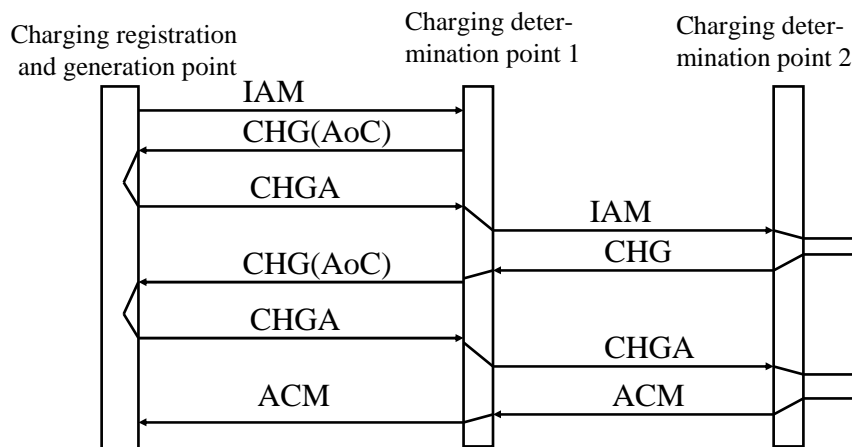

In charging generation point, info can be processed into a new form,
The registration point produces a CDR- call detail record

ISUP - more ongoing development

2. ISUP-over-IP for IP-telephony networks

- SIGTRAN group in IETF

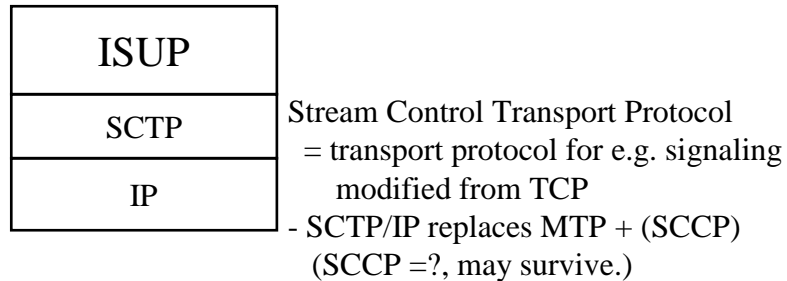

We will talk about SIGTRAN later on this course.

Discussion why DSS1 and ISUP are two different protocols

- ✓ **NB: In an IP network one signaling protocol such as SIP is used both in the user to network and network to network signaling case.**
- ✓ **Reasons favoring two different protocols:**
 - › ISDN/PSTN network stakeholder model contains subscribers and many network operators. Charging on a network to network interface differs from charging on subscriber to network interface. On the network to network interface, we may ignore who made the calls, it may suffice to count call minutes or seconds in both directions.
 - › The architecture assumes 64kbit/s timeslot infra. When used for signaling, 64 kbit/s can carry signaling for more than 1000 voice time slots. It is wasteful to use 64kbit/s for a single subscriber and allocate one timeslot on each PCM connection since each signaling channel requires its own signaling terminals in exchanges. Users do not like silent calls. Therefore, exchanges supervise the condition of PCMs. Non-functional PCMs must be taken out of use, tested and repaired, calls may need to be released on failed connections and never offered to a failed connection. Also, it must be easy to add new PCMs into the system and easily take them into use. All this requires managing states of PCMs by signaling (BLO etc). On a subscriber line, the signaling (DSS1) is carried on the same physical connection as user data/voice. So, in this case monitoring of the connection is simpler than monitoring of PCMs.
 - › If one signaling channel is responsible for >1000 calls it must be more reliable than a channel that is responsible just for < 30 simultaneous calls.
 - › Some supplementary services are implemented in a local exchange needing support from subscriber signaling but not from an exchange to exchange signaling (e.g. call forwarding, call transfer, speed dialling, ...)
 - › Identity assurance: is needed at the subscriber interface but not on a network to network interface.
 - › When ISDN was designed optimizing performance, resource usage and complexity was important!

But, yes, sure, now a common base protocol + extensions model might work as well!