

IP Telephony signalling

Overview

H.323

Summary of course scope

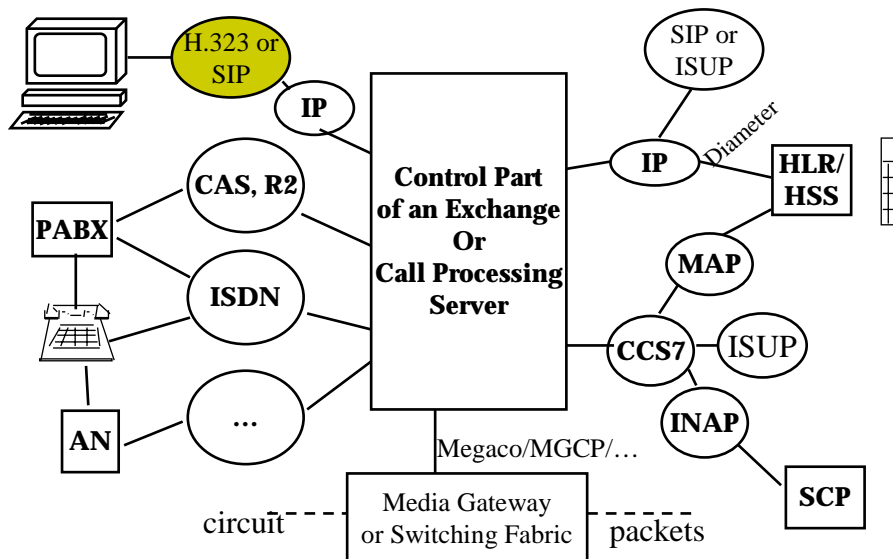

Next Generation Network (NGN) is the ETSI effort to harmonize packet telephony

The network architecture is layered in a much more strict sense than in case of CSN

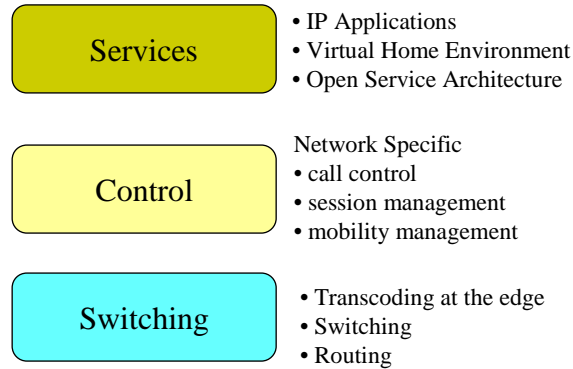

IP Telephony Signaling alternatives

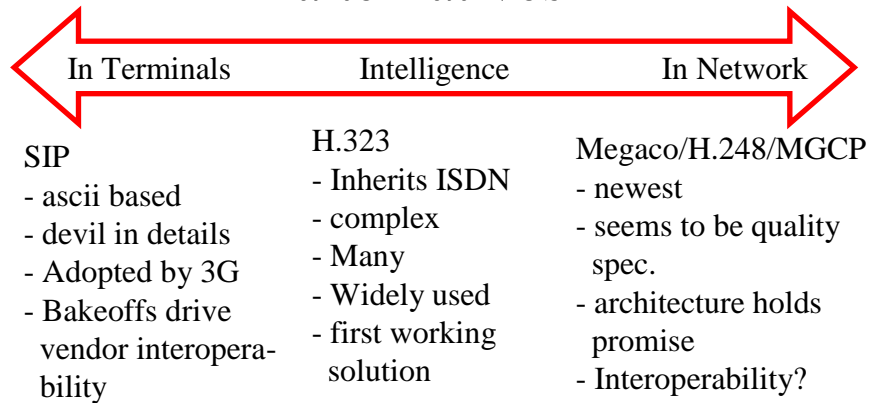

SIGTRAN works on ISUP over STCP over IP
 - many view this as an interim solution!

H.323 is a key standard for packet based multimedia communication

H.323 over: LANs, Enterprise Area Networks, MANs, Intranets, Internets
include dial-up connections and PP-connections over CSN/ISDN with PPP packet transport.

Example networks:

- Ethernet (IEEE 802.3)
- Fast Ethernet (IEEE 802.3u)
- FDDI
- Token ring (IEEE 802.5)
- ATM

MM includes:

- Audio (mandatory)
- Video (opt)
- Data (opt)

Communication = conference or two party call.

H.323 is used in IP trunking

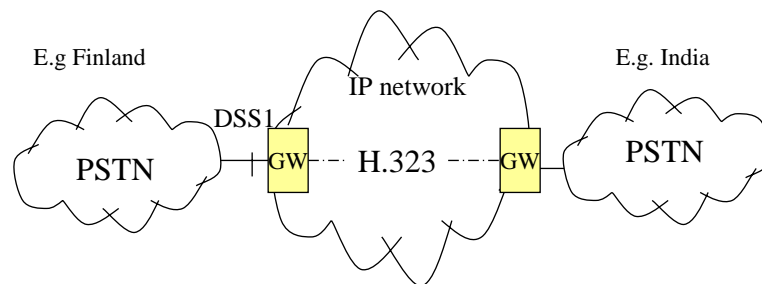

IP network is most often an Intranet, not the public Internet.

Fall-back to PSTN may be used in case of overloaded IP -network.

Makes use of arbitrage due to the regulated high International PSTN tariffs.

Initially (1997-98) a promising business - now does not look too promising.

H.323 provides also comprehensive conferencing services!

H.323 uses H.225.0, H.245 and RTP

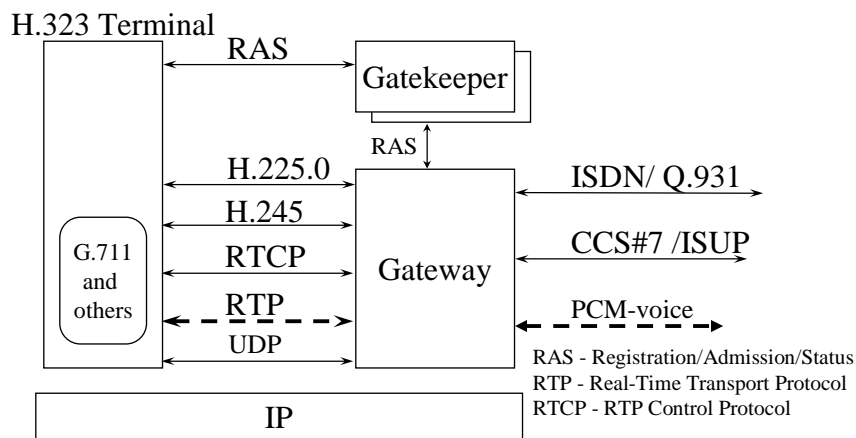

Note: this is an example configuration!

Raimo Kantola-S-2006

Signaling Protocols

11 - 7

H.323 supports many call modes

- Directly between two H.323 endpoints (no GK)
- Between two H.323 endpoints using a GK
- Many conference types
 - ad hoc multipoint conference (start with 2-party call - expand to conf)
 - broadcast conference (one sender, many receivers)
 - broadcast panel conference (mp conf + bc conf)
 - centralized multipoint conference (terminals pp to MCU, MP sends to terminals)
 - decentralized multipoint conference (no MCU - all to all coms)
 - hybrid multipoint conference - centralized audio or video
 - mixed multipoint conference (mix of decentralized + centralized modes)

Raimo Kantola-S-2006

Signaling Protocols

11 - 8

Mixed multipoint conference example

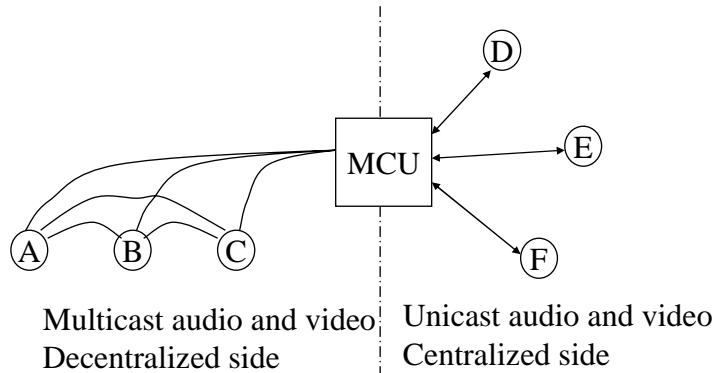

H.323 zone is controlled by a Gatekeeper

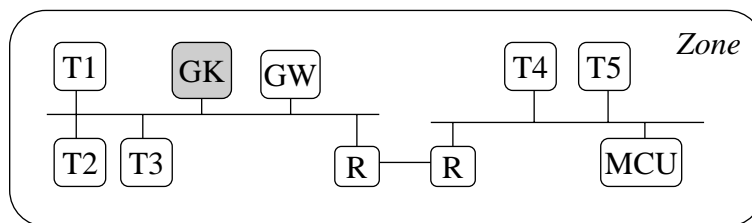

- Zone has at least one terminal, MCUs and GWs are optional.
- Zone has one and only one GK.
- Gatekeeper controls access to the network for Ts, GWs and MCUs and provides
 - address translation
 - gateway location
 - bandwidth management

GK control is not enforced, so this is an intranet solution, i.e. all parties engage in cooperation voluntarily.

Means of Control over subscribers

- Dynamic non-global IP –addresses → Internet has become only A –subscribers network. Push needs help from a server.
- NAT and Firewall can block access from the network to a user and even from the user to the network.
- H.323 – ties subscribers to a zone. SIP registration enables moving points of attachment.

H.323 terminal equipment

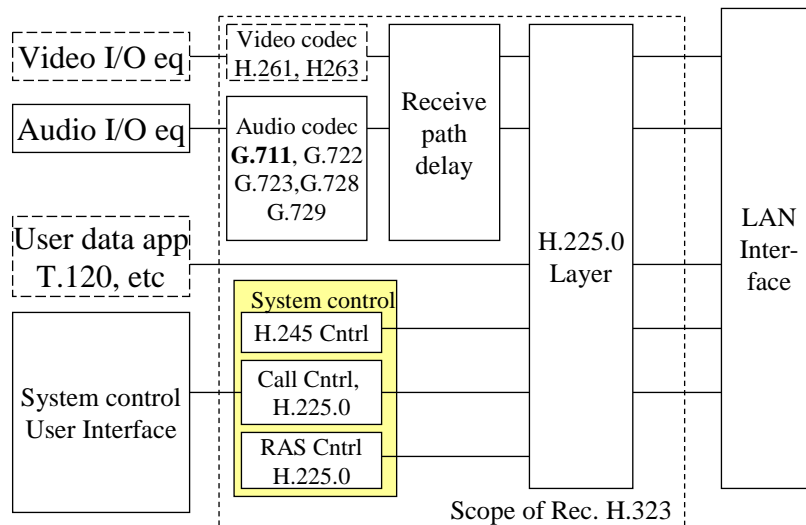

Audio and Video coding

- Audio: G.711 is compulsory (PCM –coding). In practice much more efficient coding methods are used based on negotiation.
- Video: H.261 is compulsory. H.263 (from 1995) is mentioned in H.323. Some H.323v4 products claim support of H.264 (= MPEG4 part 10) video coding.
 - H.264 coding is 2 to 4 times as efficient as MPEG2!
 - H.264 can provide TV Quality streaming at less than 1Mbps and DVD quality at about 8 Mbit/s according to <http://www.pixeltools.com/>
 - H.264 is meant for both IP based broadcast/multicast and videoconferencing.

H.323 supports many parallel addressing methods

- H.323 entity shall have at least one Network Address (e.g. IP address)
- TSAP (Transport Service Access Point) identifiers allow multiplexing several channels sharing one Network Address - map to TCP/UDP port numbers (source port, destination port).
- An endpoint may have one or many Alias addresses - may represent the Ep or a Conference that the Ep is hosting. Include: E.164 numbers, H.323 IDs (e.g. John Smith), e-mail addresses. Aliases are unique in a zone.

Gateway translates between transmission formats,
communication procedures and media formats

- Example: H.225.0 to and from H.221 (transm.f)
- H.245 to and from H.242 (comm procedure)
- Media format: Audio, video, data
- Represents characteristics of network endpoint to SCN endpoint and an IP destination to and EP connected to the IP network. May also work as an MCU
- Can also do call set-up and clearing

GK provides call control services,
when present, shall do:

- Address translation (e.g. alias to transport address using DNS + E.164 to transport address)
 - uses the translation table produced from registration messages
- Admission control: ARQ/ACF/ARJ of H.225.0
 - based on call authorization, bandwidth, other criteria
- Zone management

ARQ/ACF/ARJ – Admission Request/Confirm/Reject

GK may optionally do

- Call control signalling. May also direct the endpoints to set up the call signalling channel between themselves in a peer to peer fashion
- Call Authorization using H.225.0 signalling
- Bandwidth management controls the number of simultaneous calls in the zone
- Call management - keep list of calls -> busy conditions
- GK management, Directory service etc -

Endpoint can discover a Gatekeeper automatically

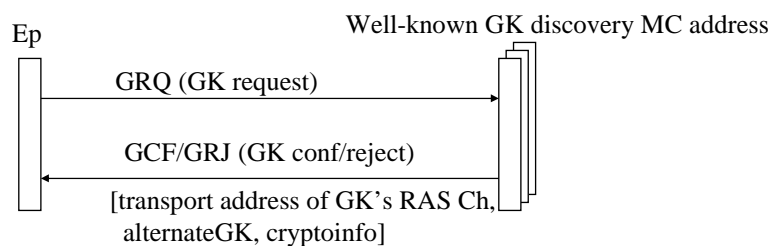

- Automatic discovery eases maintenance of individual terminals
- Terminals may also have the GK id configured

RAS signalling function

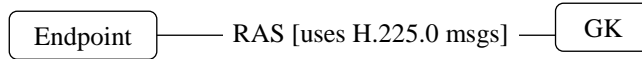

- Performs
 - Registration of endpoints, Admission of calls, Bandwidth changes for calls
 - Status
 - Disengage of endpoints.
- Uses RAS signalling channel \neq call signalling channel and H.245 control channel. GKs have a well def. TSAP id for RAS sig. channel
- Endpoint=H.323 terminal or GW or MCU (is callable)

Endpoints register using GK's RAS Channel Transport Address prior to any calls are made

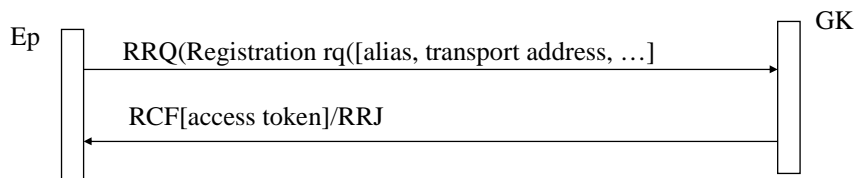

- Security policy may require that registration has time-to-live and has to be repeated from time to time.
- Endpoint or GK may un-register using the URQ message.
- The GK maintains an alias to Network Address translation table.
- Access token may be used later in call setup

Call Admission sets the upper limit for the aggregate bitrate of the call

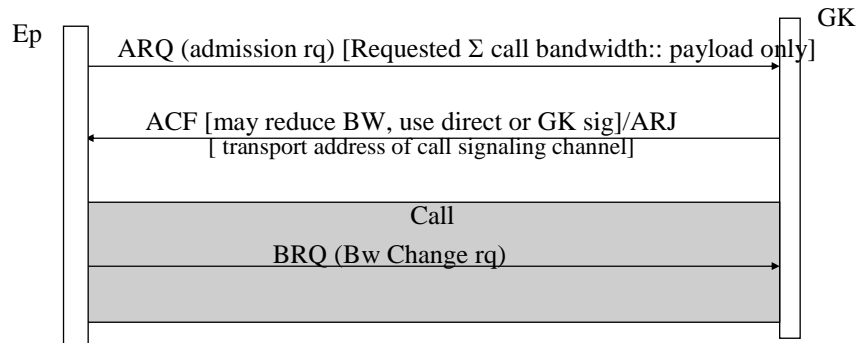

Call signalling uses H.225.0

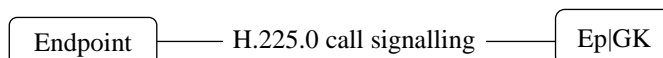

- Call signalling= call setup, request changes in Bw of a call, get status of Ep, disconnect call
- Call signalling is largely inherited from ISDN
- Call Signalling Channel is opened prior to H.245 procedures and prior to any other logical channels between endpoints. Eps have a well known TSAP id for the Call Sig. channel and a well-known Discovery Multicast address.

H.323 Call Signalling Channel Routing

- ACF has the Transport Address of the Call Signalling Channel
- The address is either a GK address or an Endpoint address.

Gatekeeper Routed
Call Signalling

Direct Endpoint
Call Signalling

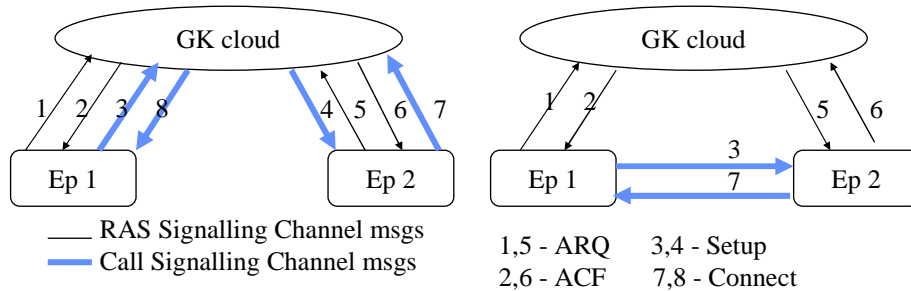

Raimo Kantola-S-2006

Signaling Protocols

11 - 23

H.245 Control Channel Routing

The goal of call signalling is the setup/release of H.245 Control Channel!

Direct H.245 Control Channel

GK routed H.245 Control

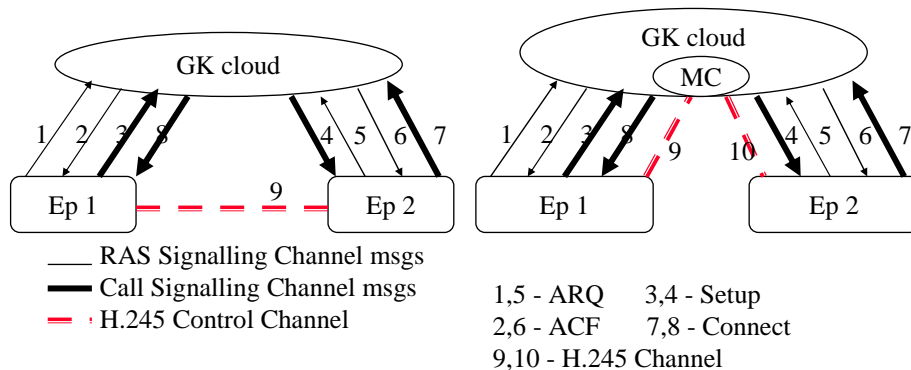

Raimo Kantola-S-2006

Signaling Protocols

11 - 24

H.245 carries end-to-end control messages between H.323 entities



- Master/slave determination for conflict resolution
- Capability Exchange (e.g. what codecs are supported)
- Logical Channel Signalling (binds media type, algorithm etc. to ports)
- Bidirectional Logical Channel Signalling
- Close Logical Channel Signalling
- Mode Request (conference modes)
- Round Trip Delay Determination
- Maintenance Loop Signalling
- H.323 also uses flowControlCommand of H.245 to limit bandwidth

Sample H.245 Logical Ch Signalling for two way RTP+RTCP communications setup

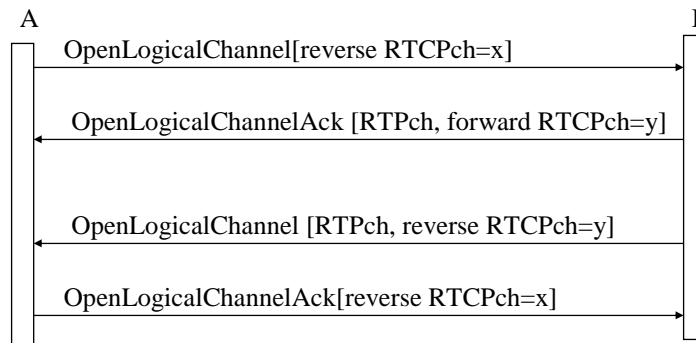

- In IP networks a logical channel corresponds to an IP port number
- Uses H.245 Control Channel

H.323 Call identification uses

- *Call reference value* - between two H.323 entities on a signalling channel (one for call signalling and another for RAS channel)
- **Call ID** - a globally unique non-zero value created by the calling endpoint passed in all H.225 messages
- **Conference ID (CID)** - in all sub-calls of a conference

Both endpoints registered - Direct/GK-routed call signalling

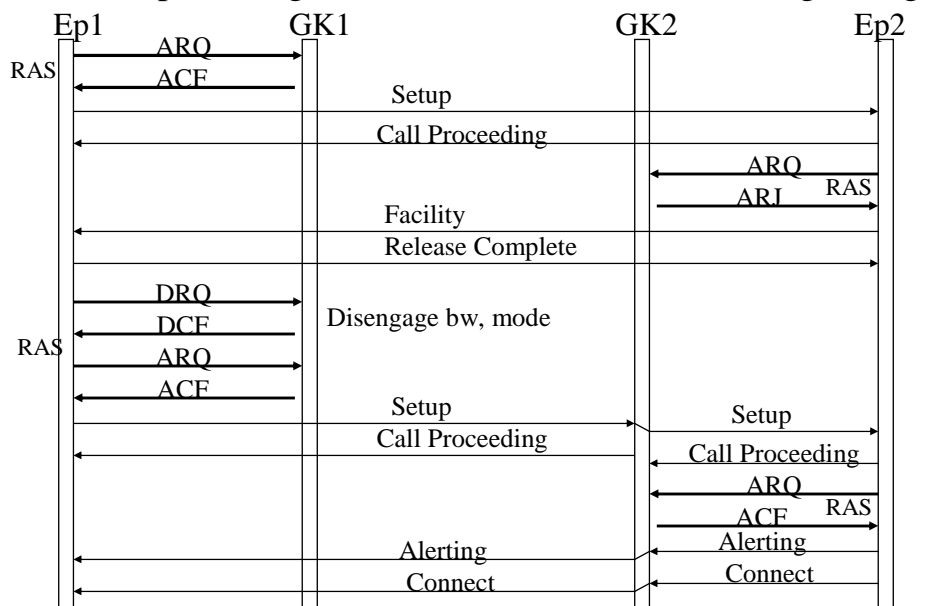

Gateway decomposition

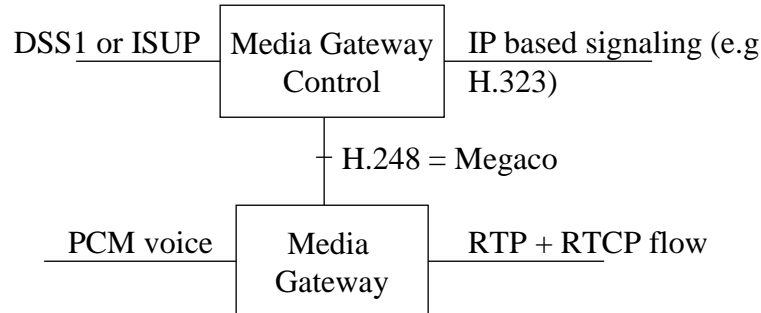

MG - Trunk gateway, residential gateway etc.
Many MGs can be controlled by one MGC, MGCs can be a mated pair --> higher availability performance.

H.323 summary

- H.323 inherits call signaling from ISDN
- H.323 has many conference modes and many signalling and call routing options
- Call setup delay is reduced by using the Fast Connect Procedure: packs all setup info from both H.225.0 and H.245 into fastStart element in *setup* and *connect* (call proceeding, alerting) messages
- Versions 1, 2, 3 and 4 are available! Version 4 products are available. Supports HTTP based 3rd party service control. ITU-T has version 5 of H.323 (quick browsing did not reveal anything major new stuff ...)
- In conferencing applications over IP H.323 is still the leader.
- Version Interoperability and Vendor interoperability are issues!
- More info e.g. in <http://www.h323forum.org/>