

## ***Signaling Protocols - 5 ECTS***

**Lecturer: professor Raimo Kantola**

**raimo.kantola@tkk.fi, SE 323 ke 10-12**

**Assistants: Juuso Lehtinen ([juuso@netlab.hut.fi](mailto:juuso@netlab.hut.fi))**

**Piia Töyrylä ([piia@netlab.hut.fi](mailto:piia@netlab.hut.fi))**

**Information:**

**<http://www.netlab.hut.fi/opetus/s383115>**

*Rka - Raimo Kantola*

© Rka -S-2006

Signaling Protocols

1 - 1

## ***Contents and goal of the course***

- ✓ Introduction
- ✓ Signaling in PSTN and ISDN
- ✓ Signaling in GSM
- ✓ Signaling over IP in wireline networks
- ✓ Signaling in 3G networks (Rel 5...)
- ✓ Inter-working of signaling systems

Signaling will be analyzed on a functional level. Focus is on understanding advantages and drawbacks of widespread solutions

***Goal of the course: To understand signaling systems used in different networks.***

***→ to understand how networks interwork.***

***→ to understand the technology trend in signaling and call/session control***

***→ to understand how switching system functionality is inherited into a packet network environment***

© Rka -S-2006

Signaling Protocols

1 - 2

## Why is signaling needed?

- ✓ **To negotiate parameters of a session between two or more parties for a voice or voice+video call**
  - to locate the other parties (one is the initiator)
  - to figure out whether the other party wishes to communicate
  - to agree technical parameters for communication
- ✓ **In circuit networks to reserve, to keep track of all circuit resources for the call and to release the resources after the call**
- ✓ **In packet networks to reserve, keep track and release logical and physical resources for the session**
  - Ports, holes in Firewalls, media processors, processes
  - To manage Quality of Service

## Networking technology studies on 38.xxx courses

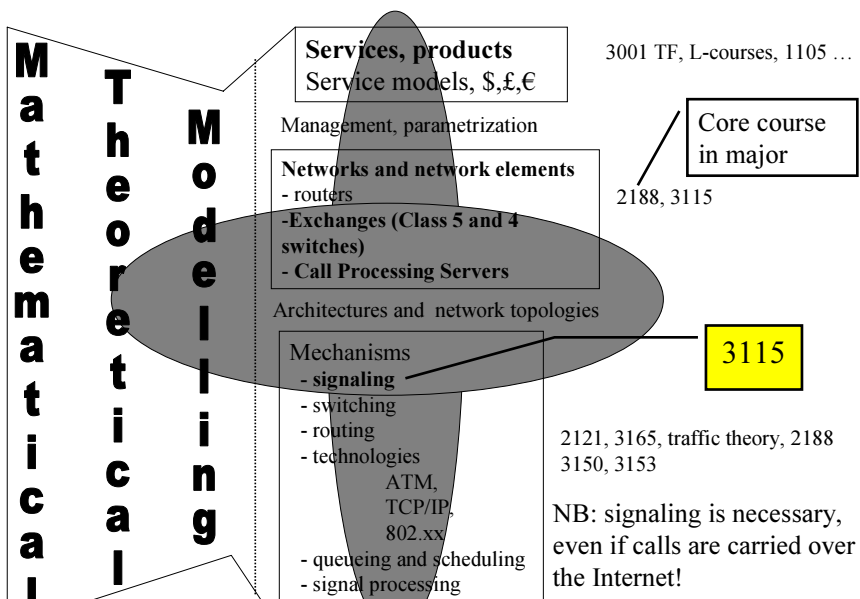

## *Course (S38.3115) Requirements*

- ✓ **These lecture notes**
- ✓ **Lectures are the best source for:** Voip, TCAP, SCCP, MTP, MAP ...
  - Do not make the mistake of thinking that you can pass the exam just by scanning through these slides! These slides have been produced to accompany oral lectures. After the lecture – these slides give you a hint of what is covered in this course. You are expected to dig the real content on the subject from other sources, in particular RFCs, 3GPP specs ...
- ✓ **RFCs, a few Internet drafts and [www.3gpp.org](http://www.3gpp.org) (for 3GPP specs)**
- ✓ **Recommended course books:**
  - Richard Manterfield: Telecommunication Signalling;
  - Gonzalo Camarrillo, M.A. Garcia-Martin, the 3G IP Multimedia Subsystem;
- ✓ **Recommended Reading**
  - Two Diploma theses on IP based signaling.
- ✓ **Exercises**
  - Mandatory simple questions to be answered after each lecture on [www](http://www) – to make sure that you build some sort of a picture of the course content during the term.
  - SIP and ENUM exercise sessions
- ✓ **Grading**
  - SIP and Enum Exercises max + 2 points, QA sessions: 0 ...2 points.
  - Mandatory: Answer Questions on the WWW + at least 1p on SIP or Enum ex.
  - Examination max 30 points

## *Quizzes*

- ✓ **We use a [www](http://www) based Questions and Answers tool. You have 7 days to answer each Quiz.**
- ✓ **On about each lecture Q = 8 to 15 questions are given requiring a simple answer of yes or no or an integer or an abbreviation.**
- ✓ **You have 4 chances to try the set of questions (each time a different set).**
- ✓ **You may earn 1 Quiz point by getting all answers right. One mistake or more gives zero Quiz points.**
- ✓ **You must get at least Q – 2 answers right to pass the Quiz. You may fail no more than 2 Quizzes to gain access to Exam. Those who failed more than 2 Quizzes, will have to give seminar talk on the lecture material for the failed Quiz.**
- ✓ **Quiz point will be scaled so that max quiz points will give 2 points towards the exam mark.**

NB: This tool has been created for the purpose of getting you to study during the term. Experience shows that those who leave it until a few days before the exam, will fail the exam.

## ***Laboratory Course S38.3133 helps to learn theory as well***

- ✓ **It makes sense to do the signaling related Laboratory works in parallel with this course!**
  - You get hand on training on many aspects of signaling.
  - This helps to form a much more realistic mental framework for all the information presented in this course.
- ✓ **The starting lecture for S38.3133 – Compulsory participation – for this term is 25.1.2006 starting at 16.15 in Hall S4.**

## ***Kie-98.010 Subject Studies in a Foreign Language (2Cu): Passing Requirements***

- ✓ (1) attend 80% of lectures,
- ✓ (2) give a talk of about 20 min in a seminar on some subject material related to the course contents (selection of the material will be presented later) and
- ✓ (3) take the exam in English.
- ✓ **The seminar presentation is required to demonstrate the so called B2 level of command of the English language. This essentially means that the presentation is fluent, it explains the ideas in a clear manner and that while a student is giving the presentation, none of the listeners are squirming or otherwise feel uncomfortable or keep wanting to help the presenter to complete the sentences. The exam answers should be completed in proper English sentences while bullet -style presentation is not sufficient. Copies of the exam papers of those students that want to take this option will be sent to the language center for Kie-98.010 grading. Note also that only those exam papers can be considered for Kie-98.010 that pass the exam on the subject matter.**

NB: This whole thing is OPEN because the Language Center does not seem to support the idea any more?

## ***Telecommunication networks - Introduction***

- ✓ **Types of telecom networks**
- ✓ **Equipment types in telecom networks**
- ✓ **Hierarchy in telecom networks**
- ✓ **Switching Systems**
- ✓ **3G network**
- ✓ **Technology trend from CSN to IP networks**

## **Communication networks can be divided into**

- ✓ **Switched Telephone Networks (PSTN, ISDN, GSM ...)**
  - CSN (Circuit Switched Networks)
- ✓ **Computer (data) networks (x.25, Ethernet, GE, Internet, MPLS etc)**
- ✓ **Specialized or Professional Networks (PMR, Tetra ...)**
  - PMR - professional mobile radio
- ✓ **This course concentrates on telephony in circuit and packet networks.**

Signaling is processed by *Exchanges* in circuit networks and by *Signaling Servers* in packet networks.

Exchanges or Switching Systems are used in  
Public Switched Telephone Networks,  
Integrated Services Digital Networks,  
Cellular Networks and  
Specialized Networks

## *Telephone Networks growth takes place in Cellular*

- ✓ Telephone networks can be divided into:
  - Fixed Networks (wireline and wireless networks)
  - Mobile networks (cellular networks)
  - Public vs private (owned and operated by a corporation)
- ✓ Growth of subscriber base takes place in cellular networks. In Fixed networks we see very little new deployment while total nrof wireline telephone subscriptions is declining.

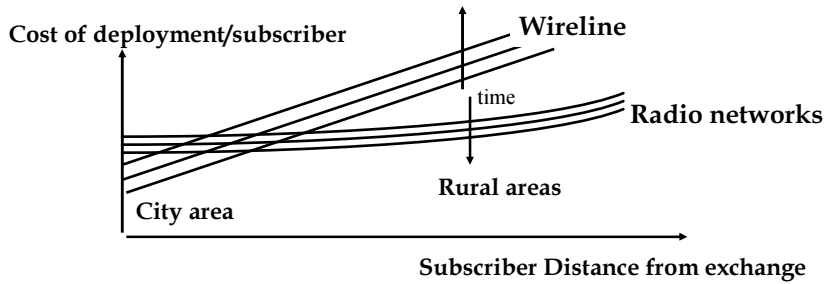

*Also: people seem to prefer to use a personal device with an intuitive user i/f !*

### World GSM Subs

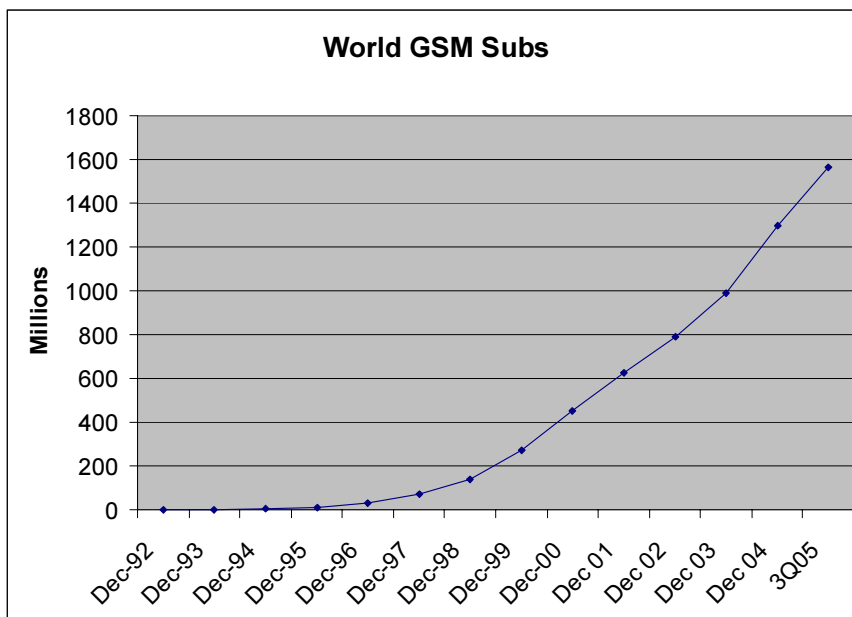

Source: GSM Association, from 4Q/2004 Wireless Intelligence.

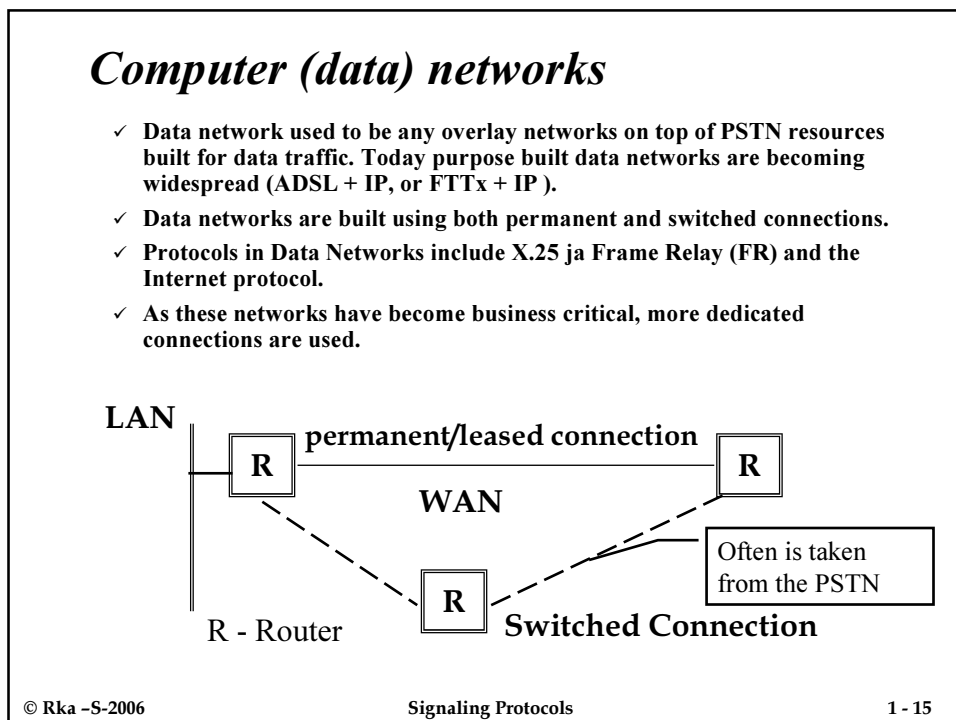
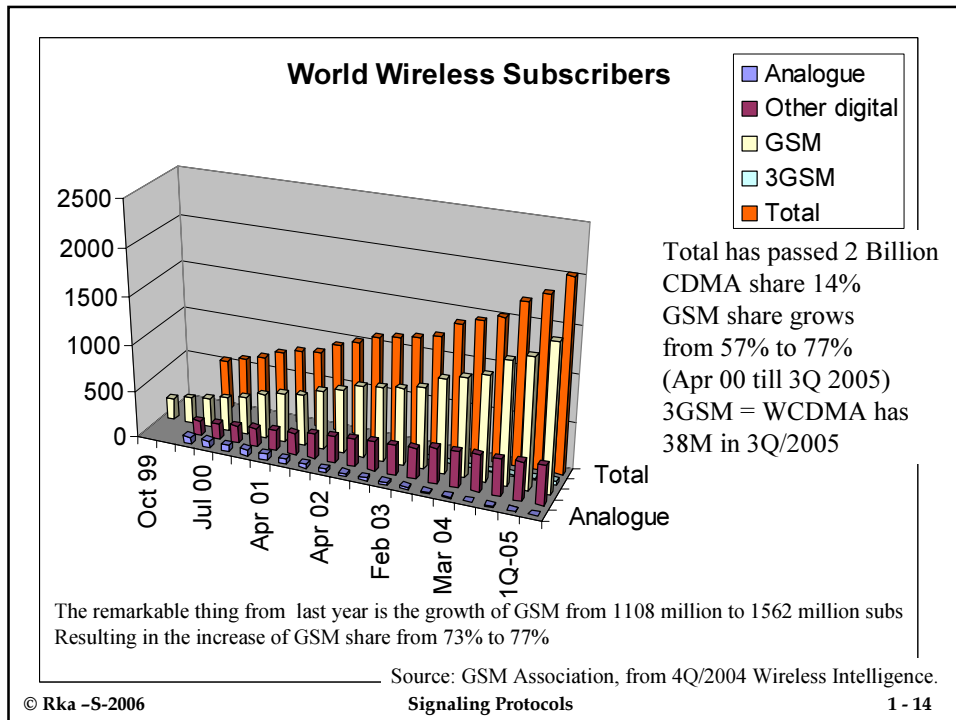

## ***Capacity requirements for Telephony***

- ✓ **Case Finland:** Nrof users: 4 million.  
Nrof simultaneous users(?): 400 000  
Each call uses 64 kbit/s.

Assume all calls are carried on one link: Capacity requirement is:

$$400\ 000 * 64\text{kbit/s two ways} = 25,6\ \text{Gbit/s.}$$

In practise 70% of calls are local. It follows that largest needed link capacities are < 10 Gbit/s (two ways).

IP network capacities:

- Current FUNET backbone links are 2,5 Gbit/s and 10 Gbit/s links!
- FUNET is supposed to serve only University people (300 000+)

## ***Future of Fixed Telephone Network***

- ✓ **In Finland Nrof wireline subscribers is declining**
- ✓ **Nrof Broadband subscribers (ADSL + CaTV) is growing quickly**
- ✓ **Major operators have started offering VOIP to BB customers**
  - service is still poorly productized
- ✓ **It is a matter of pricing of GSM services to make PSTN/ISDN telephone service unattractive to users**
  - Corporations with a lot of buying power get GSM services on wholesale prices much lower than individual GSM customers. Even the lower priced GSM subscribers are profitable.



**Scenarios for telephony:**

- All voice goes wireless
- Wireless + operator provided wireline VOIP + Free Communication Service  
Voip a'la SKYPE
- Wireless + VOIP as a feature of BB applications

A new phenom is peer-to-peer VOIP!



## *Equipment types in telecommunication networks*

✓ Based on type of usage, the equipment can be categorized into:

- Terminal equipment or CPE - customer premises equipment
- Exchanges (Switching Systems, Central Office in US)
- Call Processing Servers (e.g. 3G IP Multimedia SubSystem servers)
- Network Service Nodes (Value added Services, IN Services)
- Cross-connect Equipment
- Transmission Systems

In terms of end- to-end service Cross-Connect and transmission equipment work on OSI layers 1 and 2. Nevertheless, they contain (management) software which can be on any OSI layer. In this course we just assume that these provide the necessary bit pipes.

## *Key issues on each layer in the telecom network include*

OSI

7	Service Nodes	Intelligent Network Nodes, Voice Mail, ...	<ul style="list-style-type: none"> <li>• Differentiation, fast service creation and deployment, new service architectures</li> <li>• Interoperability, billing</li> </ul>
3	Switching Systems	<i>Exchanges, Concentrators, PBXs, Call Processing Servers</i>	<ul style="list-style-type: none"> <li>• Network design and dimensioning, routing/routeing,</li> <li>• <b>interworking (signaling)</b>, charging, <b>mobility</b></li> <li>• circuit and packet switching</li> <li>• <b>breakdown to connectivity and session layers</b></li> </ul>
2	Transmission Systems	PDH, SDH, WDM, xDSL, BSS/GSM, Radio links, Cross-connects ...	<ul style="list-style-type: none"> <li>• Coverage, large capacity (multiplexing),</li> <li>• Efficient use of radio band, radio network planning</li> </ul>
1	Circuit connections	Copper cable, cox, fiber, radio path, ...	<ul style="list-style-type: none"> <li>• Right of way, long life cycle, more efficient use of existing plant, move to FTTx</li> <li>• competition in the local loop/natural monopoly</li> </ul>

In Circuit networks signaling functionality resides in Switching Systems. In Packet networks (all IP, 3G) signaling resides on Session Layer.

## *Terminal Equipment*

- ✓ Terminal Equipment are owned and managed by the subscriber. They are used to communicate with another similar device across the network or with a Service Node in the network.
- ✓ Examples of terminal equipment types:
  - Phones, mobile phones, SIP phones, Office phones
  - Private (Automatic) Branch Exchange (PBX or PABX)
  - Modems
  - Router, bridge, LAN-switch, hub
  - Telemetric equipment
- ✓ A key assumption from the network point of view is whether TEs are Intelligent or not! This has a big impact on the choice of solutions on the switching or session layer in the network.
- ✓ Are connected to public networks using so called subscriber criteria.
- ✓ PABXs can form corporate networks. Use their own signaling methods such as QSIG, DPNSS (UK), also many proprietary signaling systems...

### *Private*

vs

### *Public telephone networks*

- |  |   |
|--|---|
| <ul style="list-style-type: none"><li>✓ Very wide set of services.</li><li>✓ Do not need to worry so much about charging but exists for company internal needs.</li><li>✓ Limited capacity nodes (PABXs) → even centralized single computer controlled implementations are present.</li><li>✓ Not everything is duplicated</li><li>✓ Wireline subscriber line requirements are eased (indoor use and line lengths)</li><li>✓ Governed by single vendor networks → often proprietary features in signaling systems.</li><li>✓ Owned by a single corporation.</li><li>✓ Is connected to a public network with subscriber criteria.</li><li>✓ Quickly moving to IP PBX/VOIP</li></ul> | <ul style="list-style-type: none"><li>✓ Rather wide set of services (but less so than in private networks).</li><li>✓ Most important feature is charging: must be accurate.</li><li>✓ Large max capacity of nodes. Distributed implementations are usual.</li><li>✓ Carrier grade quality: 2 min downtime/node/year.</li><li>✓ Must identify the subscriber accurately for charging and emergency calls.</li><li>✓ Governed by multi-vendor interworking requirements based on standards.</li><li>✓ Inter-Operator interface – inter admin accounting of calls (Network to Network Interface)</li><li>✓ Moving to NGN = VOIP+COIP</li></ul> |
|--|---|

## *Exchanges implement switched services*

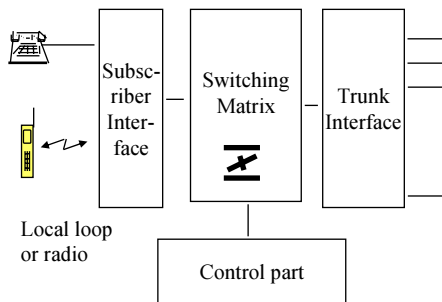

Software systems in the Control part:

- signaling and call control
- charging and statistics
- maintenance software

- ✓ Carriers of network intelligence.
- ✓ Routeing of calls.
- ✓ Responsible for service level (grade of service)
- ✓ Giants of processor capacity and software ~ computers with many external connections and a lot of real-time parallel activity.
- ✓ Maintain signaling connections with subscribers, PABXs and with other public exchanges
- ✓ May have high initial cost. Avg. Cost per subscriber is not high.
- ✓ Vertically integrate all levels of functionality – are made by a single company.
- ✓ Examples: DX 200, EWSD, AXE, 5ESS ...

## *When calls move to IP networks*

- ✓ **Connectivity and Session layers are separated**
  - On connectivity layer we have transmission and packet routing
  - On Session layer we have signaling and session control including routing of sessions
  - Call control and signaling server can reside anywhere in the IP network in relation to the caller and callee!
- ✓ **Call Processing Servers inherit most of the Exchange functionality of Circuit networks**
  - Session control (former call control)
  - Signaling
  - Charging (caller authentication etc)
- ✓ **Switching functionality of Exchanges is replaced by the packet routing infrastructure**

With static IP addresses peer-to-peer VOIP (e.g. SKYPE) is a possibility = no network based servers are needed, every user has the same application but signaling is proprietary!

## *In business terms Communication Services can be broken down to Roles and Stakeholders*

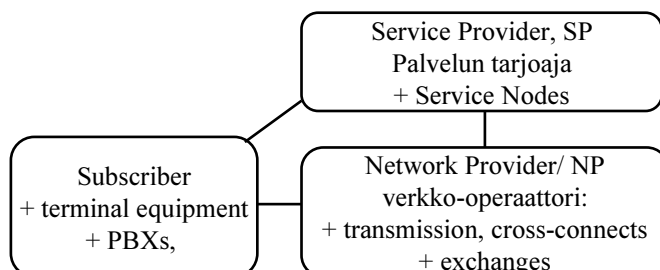

- This course analyses *signaling* which is the language used on the interfaces in the above figure.
- We will show that the real world signaling systems do not ideally match this business model.
- This has a significant impact on business boundaries: although NP business is considered dull and boring, NP is still the king! - I hope you will be able to argue on these matters after this course!

## *Telecommunication network hierarchy*

- ✓ ITU-T has specified a world wide hierarchy for the telecom network.
  - An end-to-end connection can have max 12 circuit connections out of which 4 can be international.
  - Addressing is hierarchical
- ✓ Exchange types
  - local exchange (Class 5 Switch in US)
  - originating/terminating exchange
  - transit exchange
  - long distance exchange
  - international exchange
- ✓ Traffic categories in exchanges
  - upstream, downstream
  - incoming, outgoing, internal, terminating, originating, transit

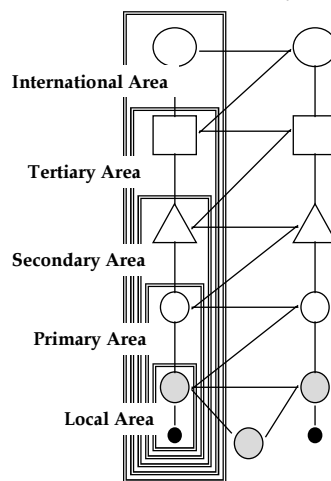

## Categories of traffic and exchanges

Upstream traffic goes up in the hierarchy.  
Downstream traffic goes down in the hierarchy.

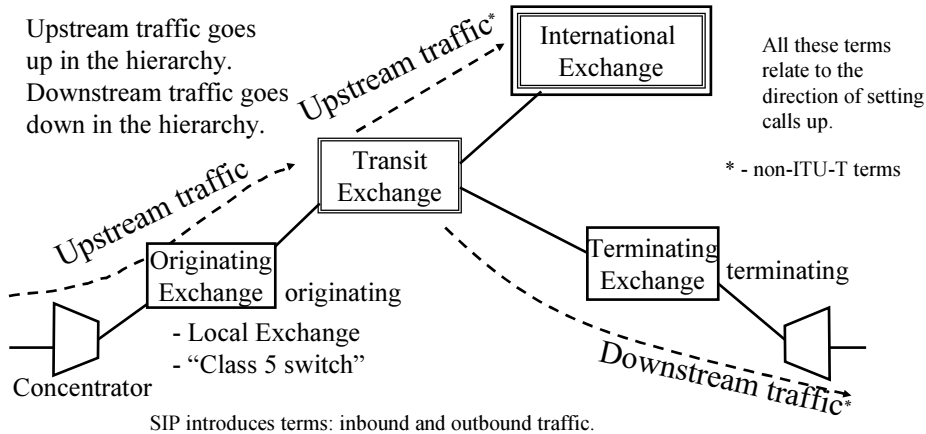

All these terms relate to the direction of setting calls up.

\* - non-ITU-T terms

SIP introduces terms: inbound and outbound traffic.

In Addition: *outgoing* traffic , incoming traffic (from the point of view of an exchange)  
Internal traffic: from one subscriber connection to another in a local exchange,  
terminating traffic: traffic that is terminated to subscribers at a terminating exchange,  
*transit traffic* = from one network connection to another.

## Service Paradigm in a Circuit Switched Network

- ✓ **A permanent capacity circuit is set up on demand and sold to the customer. The network guarantees the quality of the circuit.**
  - After set-up customers can not disturb each other.
- ✓ **The customer can use the transfer capacity as best he/she can or as poorly as he/she can.**
- ✓ **The customer pays based on used network resources (usage based charging).**

Still: have look at your regular phone bill:  
- there are lot of flat rate monthly charges!

***In the Connection Oriented Model connections are set up, and in the process the network translates global addresses to local***

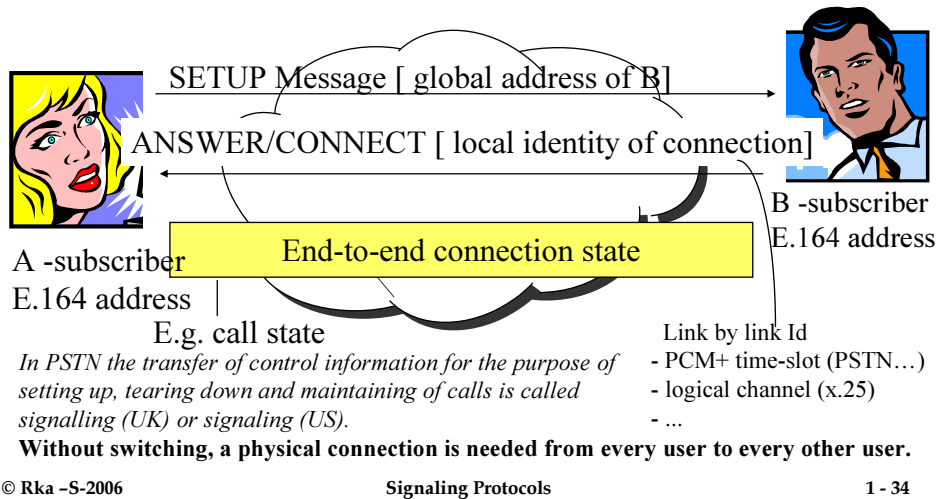

***IP network is connectionless: Caller and Callee must agree on parameters. Routing infra takes care of connectivity***

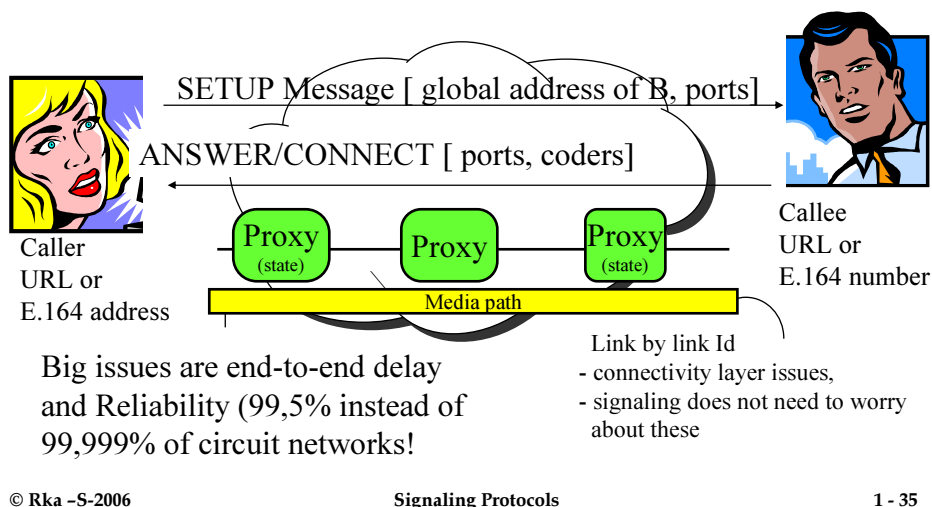

## *Connections can be set up also using network management commands*

- ✓ The PSTN was widely used for providing leased connections
- ✓ An alternative technology for leased connections e.g. for LAN-interconnection is Frame Relay transferring variable length frames or packets. A frame carries a local address. Now different types of Virtual networks (VPNs) are used for LAN interconnection (e.g. MPLS VPNs).
- ✓ Also ATM - Asynchronous Transfer Mode can be used for setting up semi-permanent virtual connections

*In this model, network nodes do not need to support (but may support) any form of signaling.*

## *Life cycles of Product Generations*

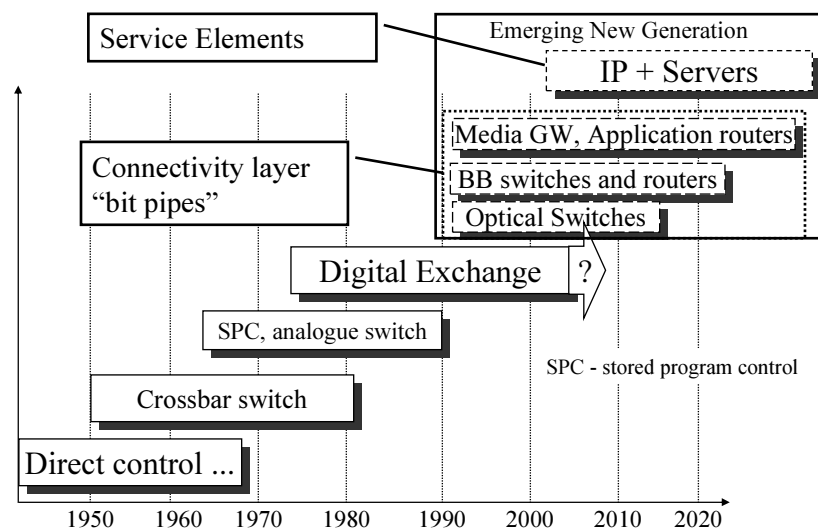

## *New element in Next Generation Networks*

- ✓ **Optical switches switch lightpaths, each lightpath can carry e.g. 2.5 or 10 Gbit/s binary stream**
  - Routing of lightpaths is a network design or dimensioning matter
- ✓ **Broadband switches and routers switch or route packets on gigabit speeds. The backplane may switch terabits.**
  - The key protocol is IP – Internet Protocol
- ✓ **Application routers (session border controllers) are placed on technology and administrative boundaries**
  - Address and port translations on admin boundaries
  - Firewall filtering on admin boundaries
  - Media translations between transmission and coding formats
  - One can view these elements as successors of switching matrices that we have on Circuit Switching Systems.
- ✓ **Servers are signaling servers and application servers. SS process signaling logic, ASs provide complicated services and may use many application level protocols (E.g. SIP, HTTP, etc...)**

## *Summary of course scope (1)*

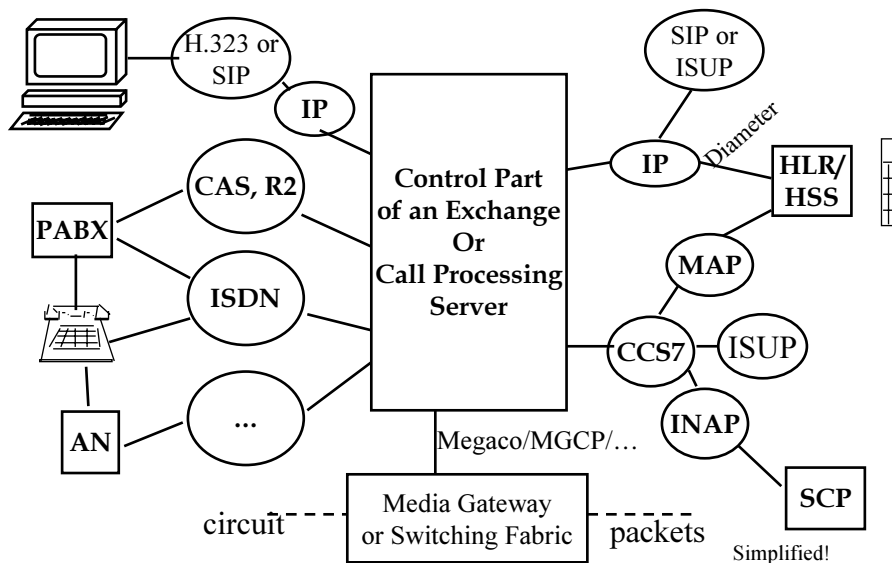



## Summary of Course scope (2): 3G

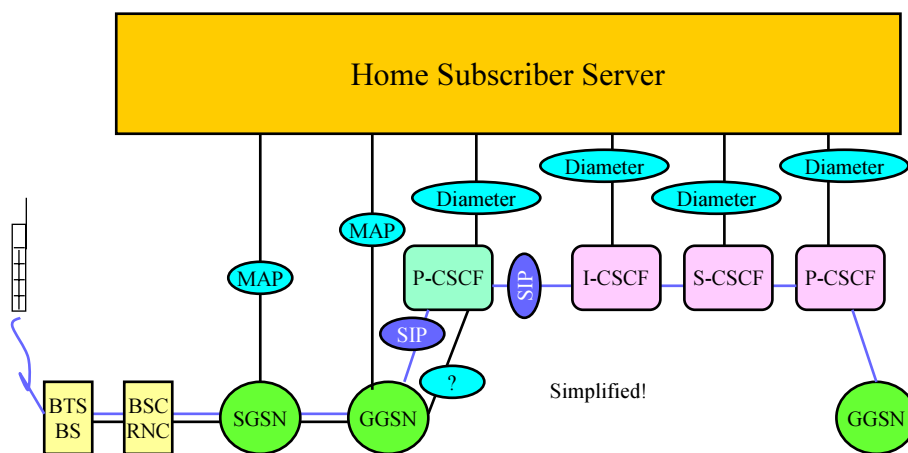

NB: 3G also has a Circuit Switched subsystem that provides switched call services!

© Rka -S-2006

Signaling Protocols

1 - 41

## Impact of IP Voice and IP Telephony

- ✓ **New signaling systems are needed but most of ISDN signaling properties will be reused or inherited**
- ✓ **Exchanges turn into “Call Processing Servers”.**
  - These will not have a switching fabric for voice signals
  - The Switching Fabric is replaced by the router network
  - In Peta- Giga- and Terabit routers a packet switching fabric is needed
- ✓ **Control plane (session layer) and the transport plane (connectivity layer) will be clearly separated:**
  - Calls are first set up as logical sessions and only when it is known that the parties involved can and wish to communicate the transfer of voice packets starts.
  - Voice packets and signaling typically take quite different paths.
- ✓ **Hybrid networks CS+PS with gateways.**
  - Gateway can be in the phone, intranet, Internet

© Rka -S-2006

Signaling Protocols

1 - 42