

Common Channel Signaling Nr 7 (CCS7)

CCS7 is a *message based, multi-layer network to network* signaling system designed for fully digital exchanges.

- ✓ Limitation of analogue signaling systems
- ✓ Basic definitions for CCS7
- ✓ CCS7 Requirements
- ✓ Functional Structure
- ✓ MTP and SCCP
- ✓ User Parts
- ✓ Strengths and weaknesses

Summary of course scope

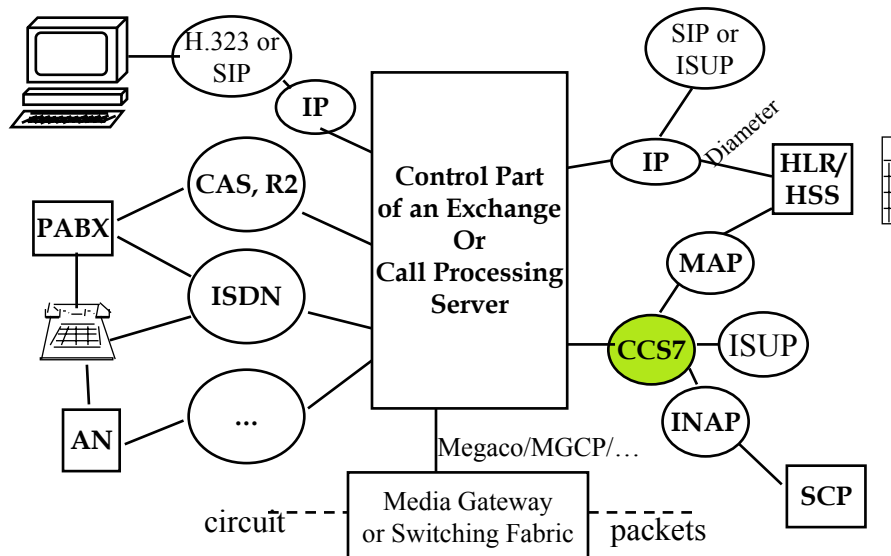

Limitations of Analogue signaling

- › **Limited set of signals --> limited set of services**
- › **Always bound to a voice path --> architectural limitation.**
- › **Difficult to change anything in an established call because registers have been released and voice channel is reserved for voice.**
- › **Slow --> uneconomical use of network resources.**
- › **MF requires special equipment - Only recently general purpose DSPs have become powerful and cost efficient enough.**
- › **HDLC on silicon --> processing hdlc frames and messages is simple and efficient on any computer.**

Does CCS7 remove all limitations?

- ✓ **Digital messages --> unlimited signal set: e.g. 2^{100} different signals can easily be devised.**
- ✓ **Common signaling channel for many voice channels (out-of-band) --> signaling is not, in principle, bound to calls nor voice/information channels. Signaling can continue during the call.**
- ✓ **Message round-trip delay on a 64kbit/s channel is ≈ 50 ms. --> post dialling delay (delay from the dialing of the last digit until the ringing tone) approaches zero.**
- ✓ **Makes use of HDLC -protocol framing and principles.**

Basis of CCS7 is the signaling network - a special kind of data network.

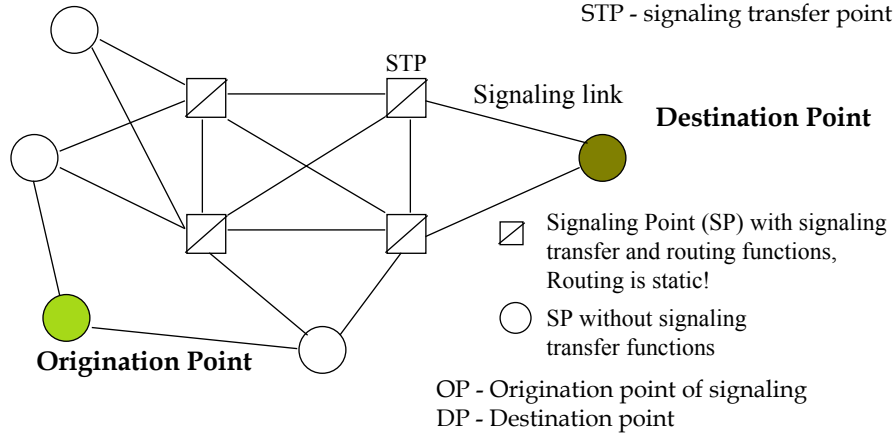

Example: In Finnish CCS7 no specialized STP -nodes were originally deployed. STP functions were integrated in exchanges. E.g in USA, specialized STP-nodes are commonplace.

Key definitions for CCS7

Signaling Point is a logical entity, e.g. in an exchange there can be one or more SPs. In one CCS7 signaling network an exchange will, however, have only one *Signaling Point Code*

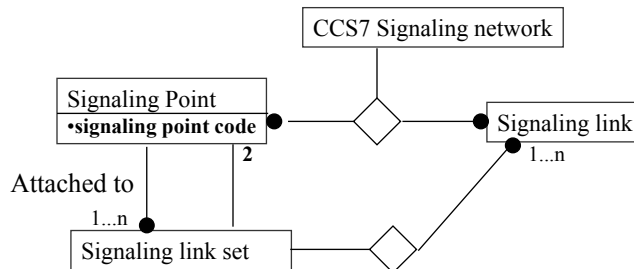

Signaling connection can be either direct or indirect (through STP nodes)

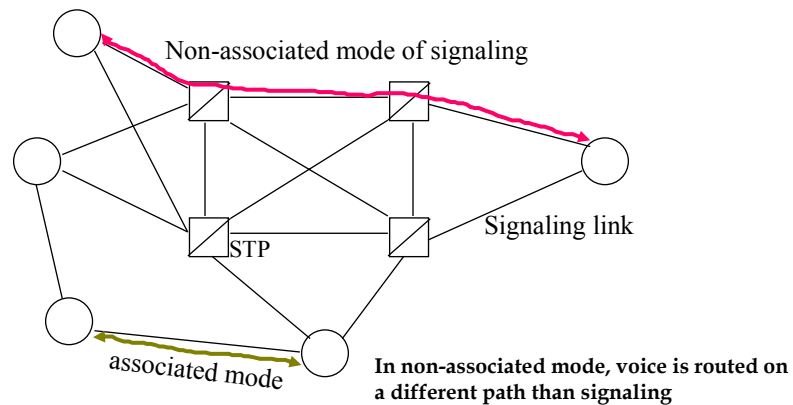

CCS7 reliability is built by software

- Speed: post dial delay (until ringing tone) $\leq 2.2s$.
- MTP:
 - unavailability of signaling route set ≤ 10 min/annum
 - share of undetected faulty signaling messages: $\leq 10^{-10}$
 - loss probability of signaling messages $\leq 10^{-7}$
 - probability of reordering or replication of signaling messages $\leq 10^{-10}$
- Expected quality of of the underlying transmission network:
 - Long term bit error rate $\leq 10^{-6}$
 - Medium term bit error rate $\leq 10^{-4}$
- Using software means reliability is increased by several 10-folds!!

Use of PCM time slots in the Finnish CCS7 network

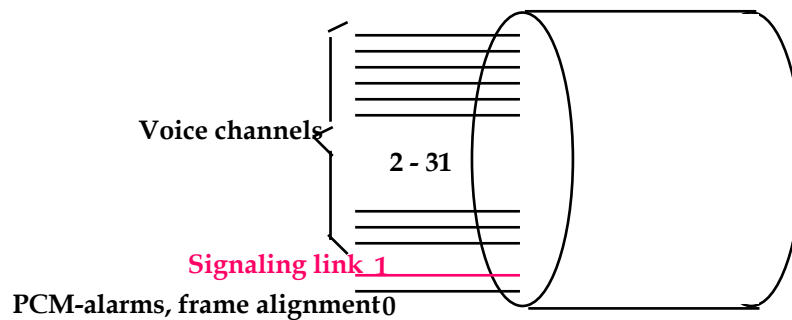

Principal components in CCS7

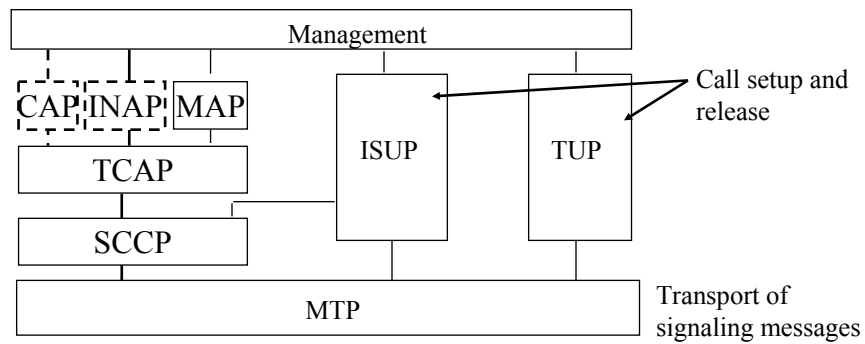

INAP - IN Application part
 CAP - CAMEL Application part
 CAMEL - Customized Applications
 for Mobile Enhanced
 Logic = "INAP"
 extension in GSM

TUP - Telephony User Part
 ISUP - ISDN User Part
 SCCP - Signaling Connection Control Part
 TCAP - Transaction Capabilities Application Part
 MAP - Mobile Application Part
 MTP - Message Transfer Part

Structure of CCS7

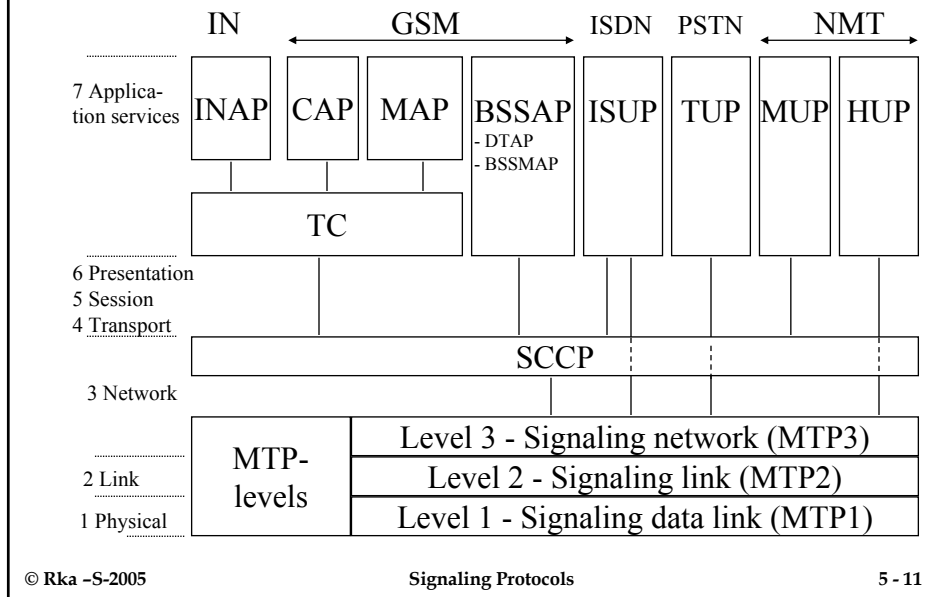

Message transfer part, MTP, is the basis of CCS7

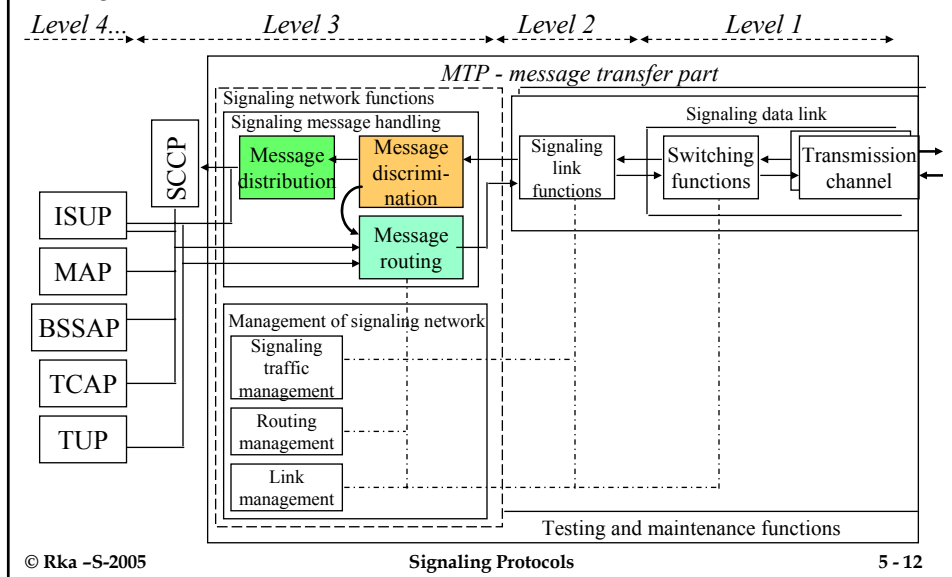

Key concepts in MTP are

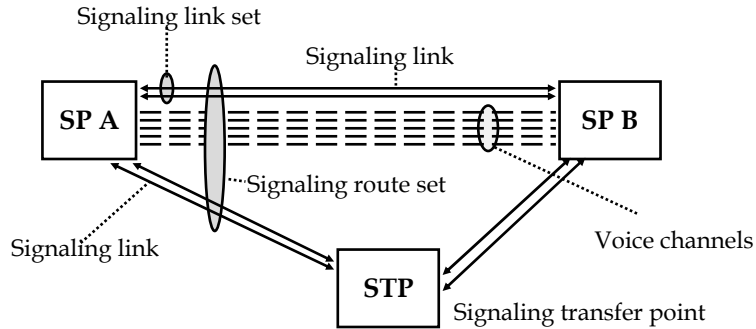

- ✓ **Signalling link** – one 64 kbit/s point-to-point channel
- ✓ **Signalling link set (SLS)** – set of sig. links with the same endpoints
- ✓ **Signalling Route** – a sequence of sign link sets between two SPs.
- ✓ **Signalling Route set** – all sign. Routes connecting two SPs.

An example allocation of MTP -functions in a Switching system (DX 200)

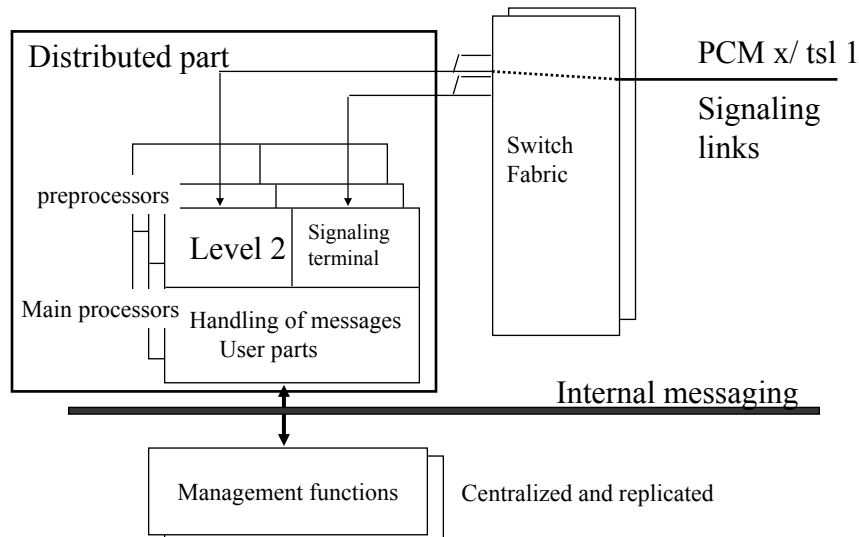

MTP - main functions are

- Switching functions: - reconfiguration of the signaling network
- LEVEL 2: Signaling channel functions: - LAPB / cmp. HDLC
 - frame alignment flags (delimiters) acc to HDLC principles
 - checksum, retransmission of message units, supervision of message ordering, acknowledgements, link fault detection and recovery

LEVEL 3:

- *Load sharing among signaling links*
- *STP and distribution to User Parts*
- *Routing is based on 14-bit (ETSI) signaling point codes.*
 - Management of signaling traffic:
 - link switchover - messages are not lost!
 - (Original) link restoration
 - forced re-routing
 - controlled re-routing

MTP has three message types

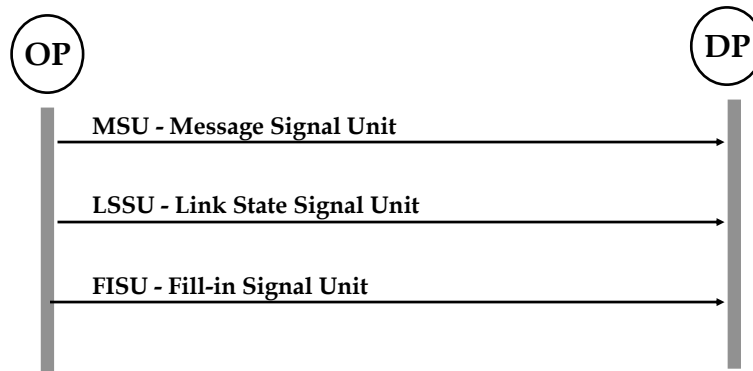

MSU - carries all payload of upper layers

LSSU - MTP level messaging between neighboring SPs

FISU - when there is nothing else to send! Originally made implementation difficult - short FISUs -> when there is no useful information to send the signaling terminal had the peak load!

Message Signaling Unit structure is

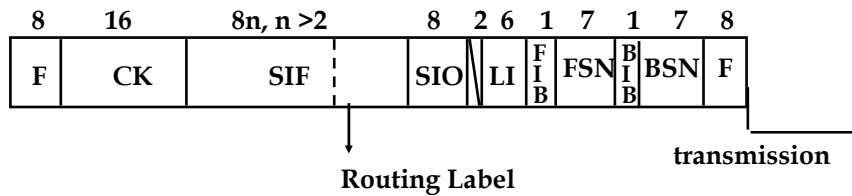

F - Flag (delimiter -01111110)

BSN - Backward sequence number

BIB - Backward indicator bit

FSN - Forward sequence number

FIB - Forward indicator bit

LI - Length indicator

SIO - Service information octet

SIF - Service Information field

= payload

CK - Check bits

Service Information Octet (SIO) defines the target application

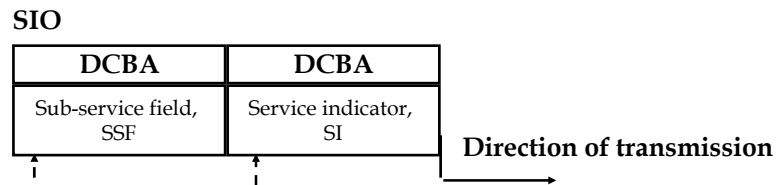

Addressing to an MTP function or a User Part or an Application Part

Network indicator: National NA0, 1 or International IN0, 1 -network.

A CCS7 network is not global. The global signaling network is formed by interconnecting CCS7 networks owned by different operators.

MTP Route Label has three fields

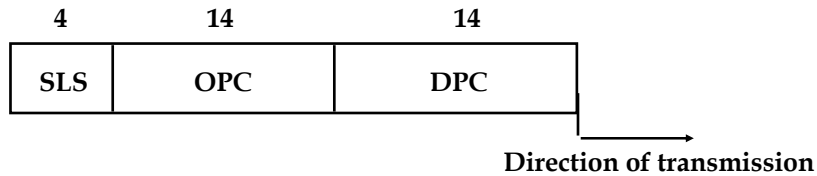

SLS - Signalling link selection (for link load sharing)

DPC - destination point code

OPC - originating point code

The shown lengths are acc to International (and Finnish) specification, in ANSI specs OPC/DPC lengths are 24 bits!

Load sharing has an impact on signal routing

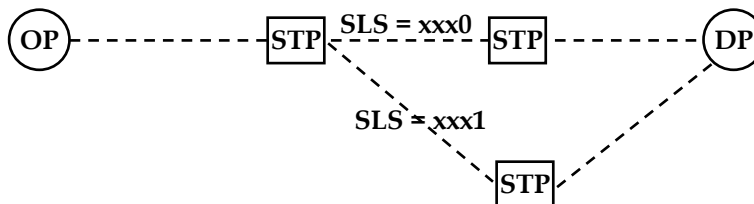

To preserve the order of signals, higher levels set the SLS value so that the route remains the same e.g. for all signal messages of a single call.

Flow of signaling messages in case of International GSM location update

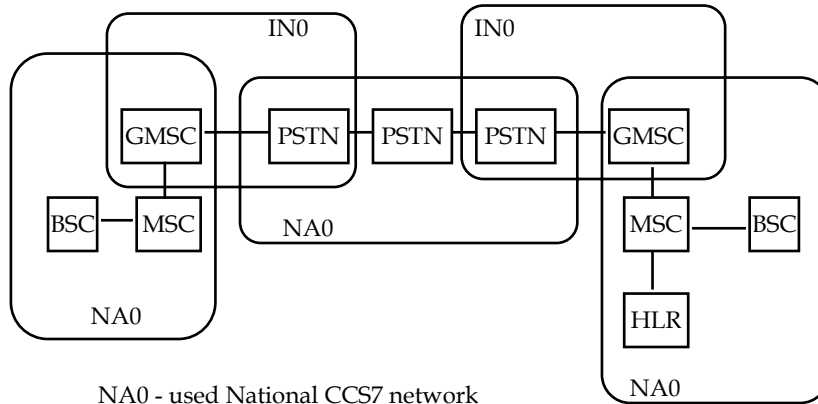

NA0 - used National CCS7 network
IN0 - used International CCS7 network

Signaling Point Codes are unique only in one signaling network !!

SCCP - Signalling Connection Control Part expands MTP networking services

- ✓ **MTP uses 14-bit signaling point codes as addresses - this is not enough in the global network.**
- ✓ **No relationship to voice channels: SCCP can be used to signal events that are unrelated to calls (such as location updates in mobile networks).**
- ✓ **SCCP brings Global Title - an extension to the addressing mechanisms provided by the MTP.**

Fourth level is needed, when MTP-signal message routing is not enough

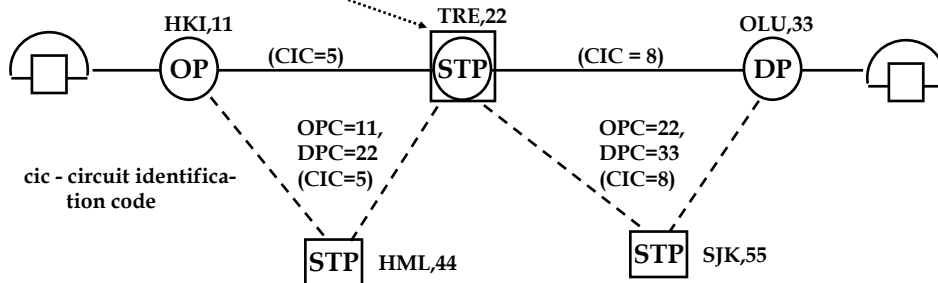

- Messages/calls through an international signaling point
- Calls across an operator boundary
- Intelligent Network calls
- In general, when the OP does not know the location of the called party

4th level = SCCP or a User Part.

If signaling is call related – UP, if not SCCP. If UP usually no SCCP is needed.

SCCP provides four service classes

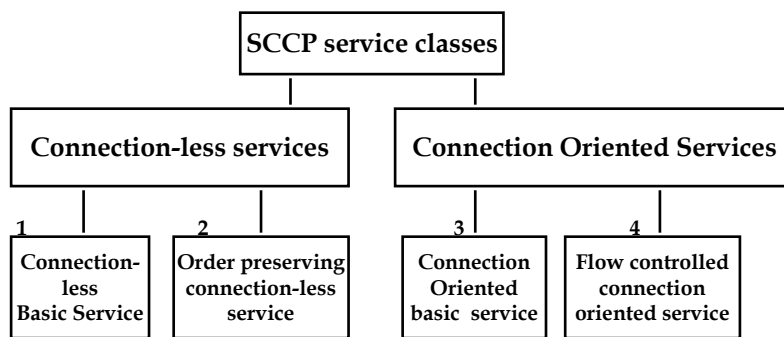

virt. IP

✓ Connection Oriented message transfer

Only classes 1 ...3 are in use.

- › on demand connections as a service to UPs
- › permanent connections with management commands

Global Title in SCCP supports global messaging over the CCS7 network

Calling and called party in SCCP

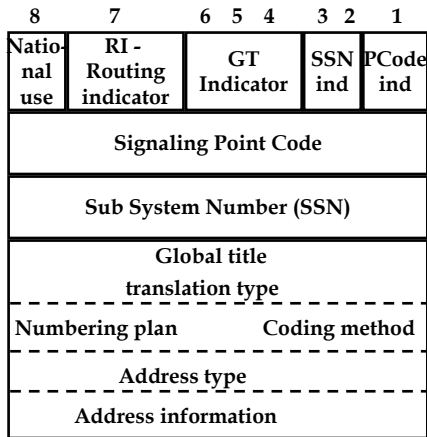

SSN (cmp. Port Numbers in TCP/IP)

- 1 - SCCP management
- 2 - TUP
- 3 - ISUP
- 4 - OMAP - Operation and Maintenance AP
- 5 - MAP - Mobile AP
- 6 - MAP/HLR
- 7 - MAP/VLR
- 8 - MAP/MSC
- 9 - MAP/EIR - Equipment Id reg
- 10 - MAP/AuC
- 11 - ISUP/SS ISUP supplementary services
- 12...247, 249...252 reserved
- 248 - MUP (NMT Mobile UP
- 253 - OMC - Operation and Maintenance Center
- 254 - BSSAP - BSS Applic. part

Address Information in GT of SCCP can be a telephone number or a subscriber identity

E.212: IMSI: MCC MNC MSIN E.g. 244 05 87654321

E.164: MISDN: CC NDC SN E.g. 358 40 540 3127

E.214: Hybrid: CC NDC MSIN E.g. 358 40 87654321

IMSI - International Mobile Subscriber Identity
 MCC - Mobile Country Code
 MNC - Mobile Network Code
 MSIN - Mobile Subscriber Identity Number
 CC - Country Code
 NDC - National Destination Code
 SN - Subscriber Number

A use case of addressing

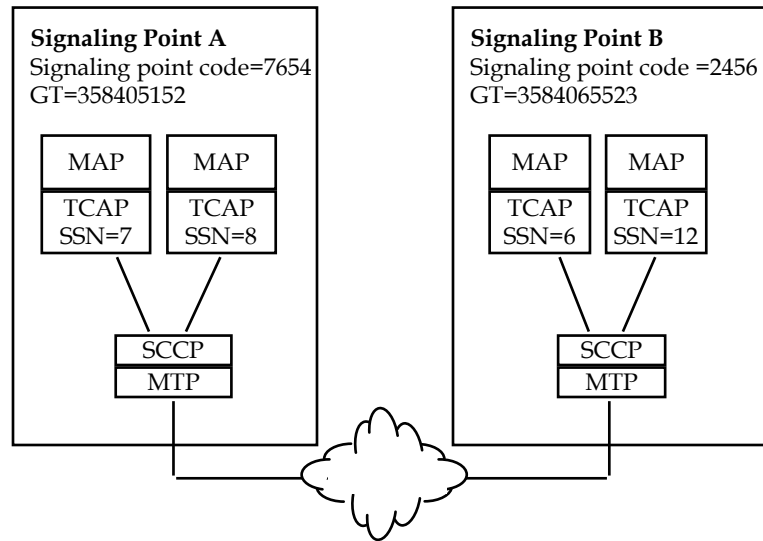

User Parts (Ups)

For call setup, release and supplementary services!

- ✓ **TUP - Telephony User Part - oldest and simplest**
 - › National variants!
 - › Messages bound to voice channels with **Circuit Identification Code (CIC)** in every message
- ✓ **ISUP - ISDN User Part**
 - › supports wire-line ISDN calls
 - speech, 64kbit/s, multi-channel: 128, 384, 1536, 1920 kbit/s services
- ✓ **MAP - Mobile Application part -**
 - › used in GSM e.g. for HLR - MSC communication
 - › provides mobility management

CCS7

Strengths

- ✓ Large number of signals
- ✓ message based -> native for digital exchanges and computers
- ✓ out-of-band --> signaling can continue for the duration of the call and even independent of any calls
- ✓ Reliable
- ✓ MAP - provides mobility management

and

weaknesses

- ✓ Complicated to implement
- ✓ Heritage of a closed market
- ✓ Service dependent - new services require new fields into signaling messages and thus software upgrades in exchanges
- ✓ Requires new features to be secure in a competitive multi-operator environment

* At its best overlying a rather unreliable base network, reliability has been enhanced by software functions.

The current CCS7 environment may have potentially hostile third parties

