

Integrated Services Digital Network

- ✓ **Some repetition**
- ✓ **ISDN access**
 - › structure
 - › interfaces
 - › physical layer
- ✓ **ISDN signaling**
 - › bearer and telecommunication services
 - › layer 1
 - › layer 2
 - › layer 3

Summary of course scope (1)

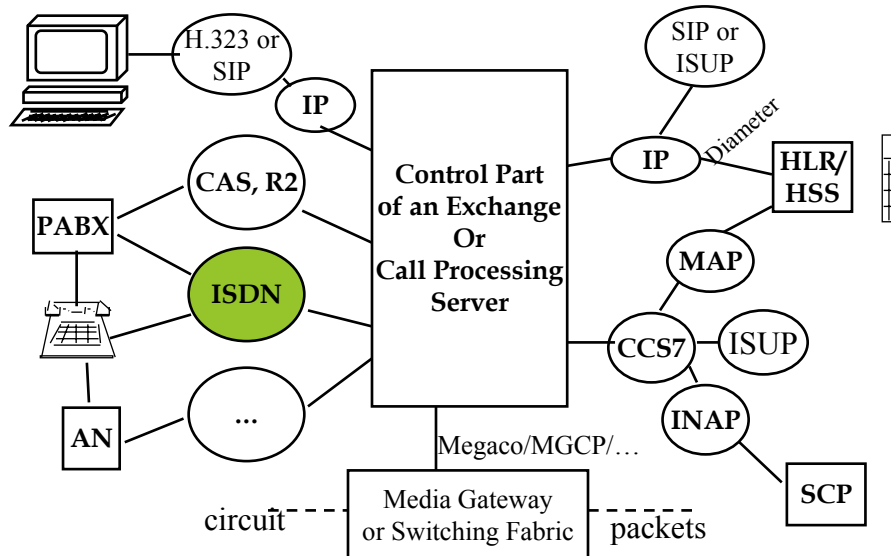

Some repetition

- ✓ Channel Associated Signaling (CAS) is tightly tied to the voice channel either in space, time or frequency -> no signaling unless voice channel is reserved.
- ✓ In in-band signaling, the voice path itself is used to carry signals.
- ✓ CAS has many limitations: in a PCM -frame one tsf needs to be dedicated to signaling and a multi-frame of 16 frames needs to be maintained. The set of signals is limited.
- ✓ Channel Associated R2-signaling is the first widely adopted, standardized CAS signaling system (but still not and will never be used in every country).
- ✓ Call setup or register signaling vs. line signaling may use different representation of signals as well as different channels to carry the signals.
- ✓ Any CAS system provides only a limited set of signals, often their semantics is context dependent.

ISDN -access has a set of standardized interfaces

- ✓ ISDN-access provides a bus for connecting user terminals, the max of 8 terminals can be attached.
- ✓ Many interfaces are specified between logical entities in the access

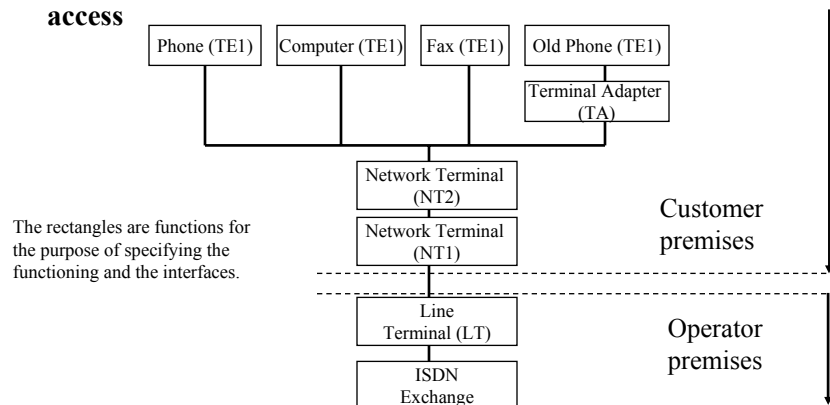

ISDN Basic Interface provides 2 x 64kbit/s to the user

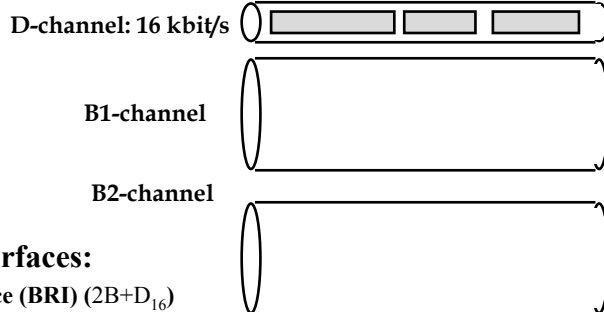

✓ **Two types of Interfaces:**

- › Basic Rate Interface (BRI) (2B+D₁₆)
- › Primary Rate Interface (PRI) (30B+D₆₄)

✓ **BRI provides two B-channels for information transfer and a signaling channel (D-channel) :**

- › Two independent terminals can use one B-channel each at a time.
- › The main purpose of the D-channel is transport of signaling between the terminals and the local ISDN exchange. Packet mode transfer is used on the D-channel.

Message based signaling systems

- ✓ Message based signaling has been developed to improve the control possibilities of the network by terminals.
- ✓ Message based signaling can be used only by Computer controlled, fully digital exchanges.
- ✓ Message based signaling is natural for computers - the signaling information is largely in the same format in which it is processed and stored.
- ✓ Message based signaling is based on ITU-T:n SS6 (now CCS7 and ISDN) recommendations.

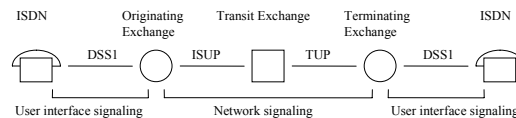

DSS1 – Digital Subscriber Signaling System No 1, ISUP – ISDN User Part, TUP – Telephony User Part
 ISDN – Integrated Services Digital Network.

ISDN Access and ISDN Interfaces

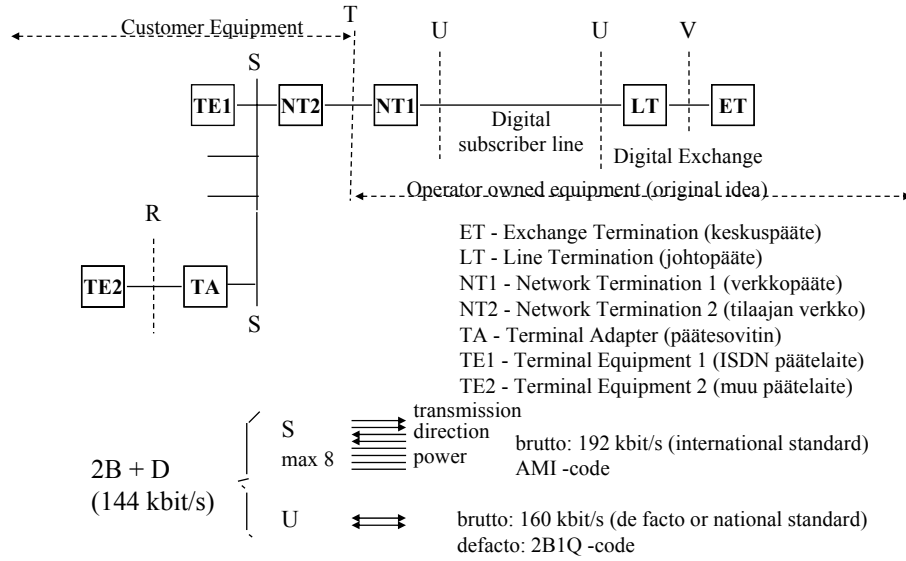

NB: It is also possible that the user buys the NT1 box himself or herself.

Examples of line codes

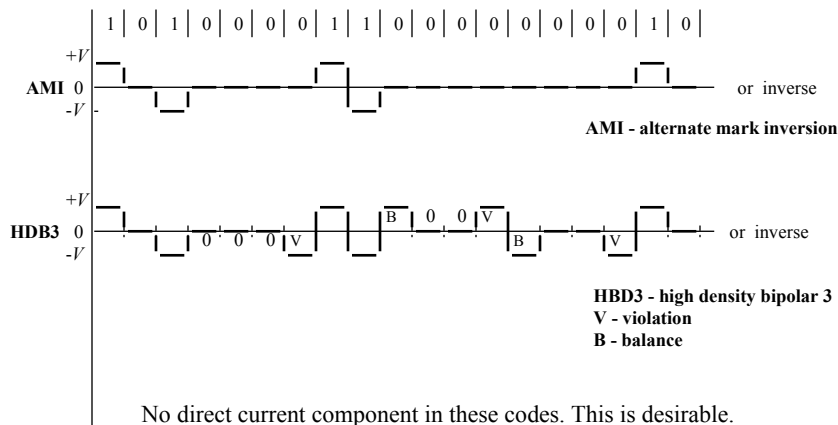

HDLC - transfers frames, delimited by 0111 1110 delimiters.

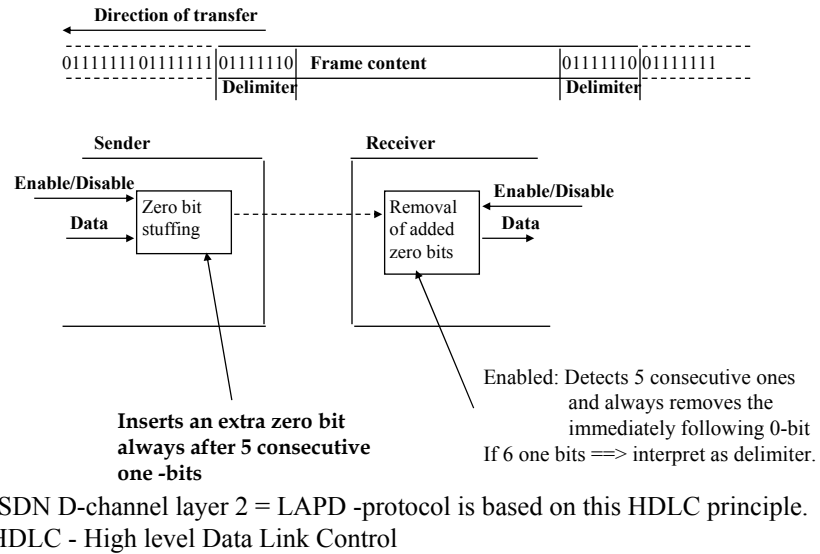

© Rka -S-2005

Signaling Protocols

4 - 9

HDLC Sender

```

Do forever
  count=0
  Do While Enable
    if databit=1
      count=count+1
      if count = 5
        send 0
        set count = 0
      fi
    else
      set count = 0
    fi
  send databit
  End do while enable
  If disable
    send 01111110
  fi
End
    
```

HDLC Receiver

```

Do forever
  When 01111110 received
    count=0
    set Enable
    Do While Enable
      if databit=1
        count=count+1
        if count = 6
          01111110 received !
          set disable
        else
          pass databit (to) onwards
        fi
      else if databit = 0
        if count = 5
          remove 0
        else
          pass databit (to) onwards
        fi
      set count = 0
    fi
  End while enable
  if disable
    remove tail 011111 from onwards
    pass frame from onwards to the upper layer
  fi
End do forever
    
```

© Rka -S-2005

Signaling Protocols

4 - 10

(U ja V) -interfaces

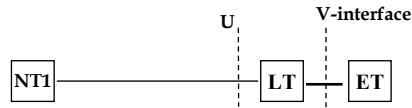

- ✓ **Network Termination NT1 is connected to the exchange Line Termination using the U-interface.**
 - › Data transfer takes place on a twisted pair copper cable (BRI), the bit rate is 160 kbit/s bi-directionally (full duplex).
 - › In Finland (originally in US) multi level code 2B1Q is used (-> baud rate is 80 kbaud).
 - › Bi-directional full duplex transfer is based on echo cancellation: both parties send at the same time, receiver deducts what it has just sent, gets what the far end has sent!
- ✓ **On the V-interface a number of specifications may be used.**
 - › V1-interface applies for the Basic rate interface.
 - › V3-interface is meant for PBXs with a capacity of $30B+D_{64}$ channels.

(S, T) -Interfaces

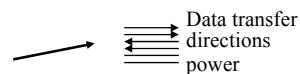

- ✓ **S-interface is meant for terminals.**
 - › The interface is a bus by structure
 - › 8 ISDN terminals can be connected.
 - › Transfer in both directions uses 4 wires.
- ✓ **T-interface is meant for PBXs**
 - › Resides between network termination NT1 and an ISDN-PBX (= NT2).
 - › T0-interface = S0-interface and is used in PBXs that can serve only BRI connected users.
- ✓ **T2-interface is meant for corporate PBXs**
 - › Transfer rate is 2048 kbit/s.
 - › T2-interface has 32 channels with 64 kbit/s. Of those 30 are normal B-channels, one is the D-channel and one is used for synchronization. I.e. the structure is like a PCM.

R -interface

- ✓ R-interface separates the Terminal Adapter and a non-ISDN device from each other. It follows some existing specification understood by the non-ISDN device (e.g. V.24, V.35 or X.21 - protocol specification).

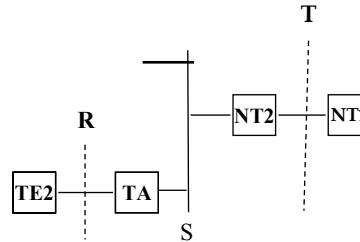

In practice logical functions are grouped in the equipment

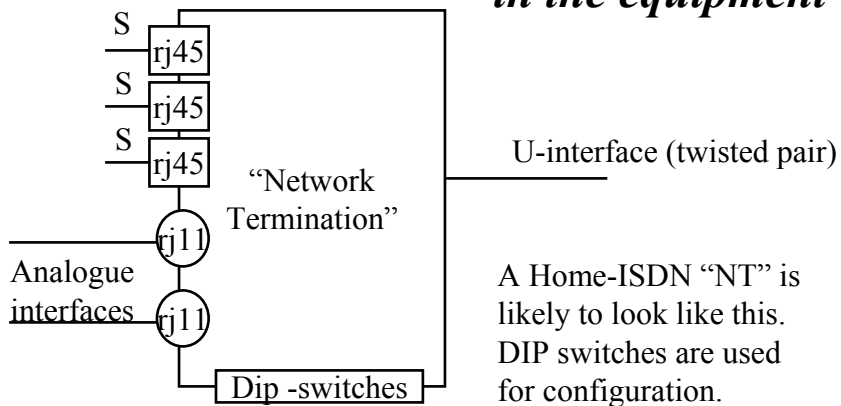

Here physical "NT" = NT1+TA(for analogue phones)

Communication between NT and a Terminal

- ✓ AMI -line code is used between a Terminal and the NT (AMI, Alternate Mark Inversion).

Sent bit	0	1	0	0	1	0	0	0
AMI signal	-1	0	1	-1	0	1	-1	1

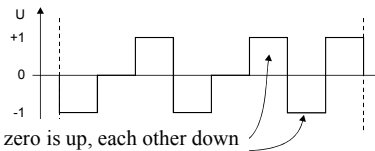

- ✓ When there is no traffic over an ISDN interface, terminals are deactivated. A continuous INFO 0 signal is on the interface.

Activation of the basic rate interface

- ✓ Terminal starts activation by sending a continuous activation request: INFO 1. When the network detects the request, it starts sending synchronization frames INFO 2.
- ✓ When the network initiates activation, it starts sending INFO 2 directly.
- ✓ When the terminal detects a synchronization frame, it stops sending the activation request signal and starts sending active state frames INFO 3. When the local exchange has received active state frames, it moves to INFO 4 state. The physical layer is now active and ready for information transfer.

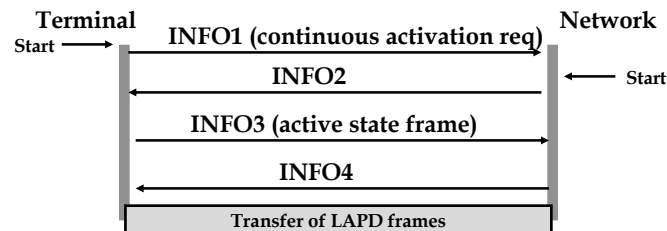

Frame structure on the S-interface

- ✓ 48 bit frames 4000 times per second are used between a terminal and the NT1.
- ✓ The resulting bit rate is 192kbit/s

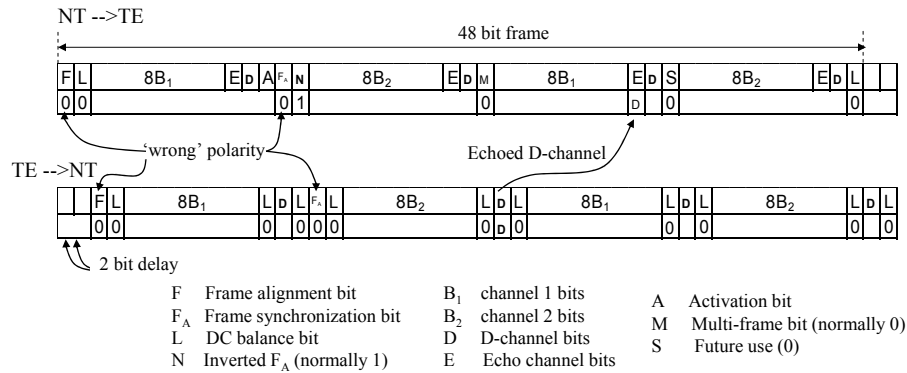

© Rka -S-2005

Signaling Protocols

4 - 17

Frame synchronization

- ✓ Frame synchronization is achieved by sending violation bits in the AMI code.
- ✓ The first (F) and the 14th bit (FA) equal to zero with a wrong polarity I.e. the same as the previous zero. To balance this for the sake of zero average voltage, the wrong zero is followed by DC balance bit (L).

NB: On S-interface the AMI code is inverted, I.e. logical zero is sent as a pulse with alternating polarity and a logical 1 is sent as zero voltage.

© Rka -S-2005

Signaling Protocols

4 - 18

Overhead bits in the frame carry D-channel echo and control power consumption

- ✓ **A Terminal can see that the NT has received its D-channel bits based on E(echo)-bits. NT copies a received D-bit to the next E-bit.**
- ✓ **A-bit is used for power control. With A-bit, the network can command the terminals to deactivate themselves and to transfer to a low power mode in which they are only able to become active again either on network request or user action. The activation procedure uses the A bit.**

Message based signaling can be functionally split following the OSI 7 layer model

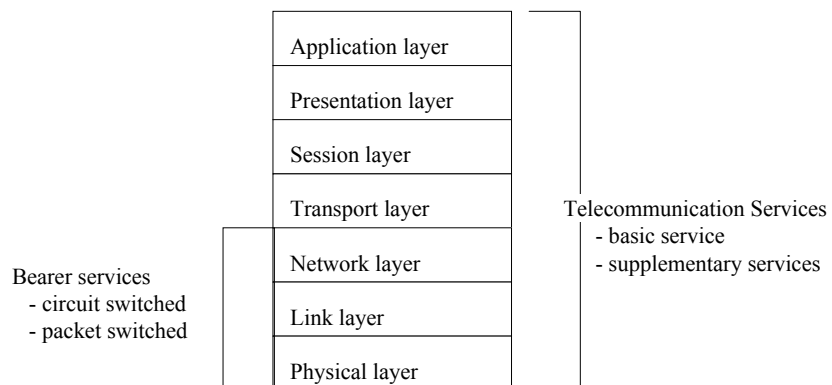

Bearer services are transport services that are seen by the “user”

✓ **Circuit switched bearer services include:**

- › Speech
- › 3,1 kHz audio
- › 7 kHz audio
- › transparent 64 kbit/s.

✓ **Packet switched bearer services include:**

- › virtual call and permanent virtual connection,
- › connectionless packet switched service on the D-channel,
- › user-to-user signaling information.

Telecommunication Services incorporate all OSI layers

- ✓ **A Telecommunication service is a set of functions offered to a user and it is implemented using the capabilities of all OSI layers.**
- ✓ **Telecommunication services make use of the bearer services.**
- ✓ **Telecommunication services can be further divided into basic and supplementary services.**
- ✓ **Supplementary services can be used only in connection with a basic service.**

Digital Subscriber Signaling System No 1 (DSS 1)

- ✓ **DSS1 is based on a protocol stack that includes three OSI lower layers.**
- ✓ **DSS1 is fully message based and out-of-band offering the possibility of signaling while the voice channel is open end-to-end.**
- ✓ **DSS1 messages are sent on the D-channel.**
- ✓ **DSS1 layer 2 follows the HDLC principles and is called the LAPD-protocol (Q.920 - Q.921).**
- ✓ **DSS1 signaling overview is given in ITU-T Q.930 and detailed procedures are given in Q.931.**

Q.920/Q.921 - LAPD

- ✓ **Connectivity over the link between a terminal and the Local exchange**
 - › Inherits HDLC principles.
 - › Corresponds to the OSI layer 2 requirements
- ✓ **Transfers frames from *many terminals to many layer 3 entities*.**
- ✓ **Properties:**
 - › **DLCI - data link connection id identifies the link connections: DLCI = SAPI + TEI. SAPI = Service Access Point Id, TEI = Terminal Endpoint Id - are purely layer 2 concepts. Layer 3 uses CEI - Connection Endpoint Id = (SAPI+CES)**
 - › **Can guarantee frame order due to numbering.**
 - › **Fault management - lighter than MTP in CCS#7.**
 - › **Flow control based on windowing.**

LAPD frame format

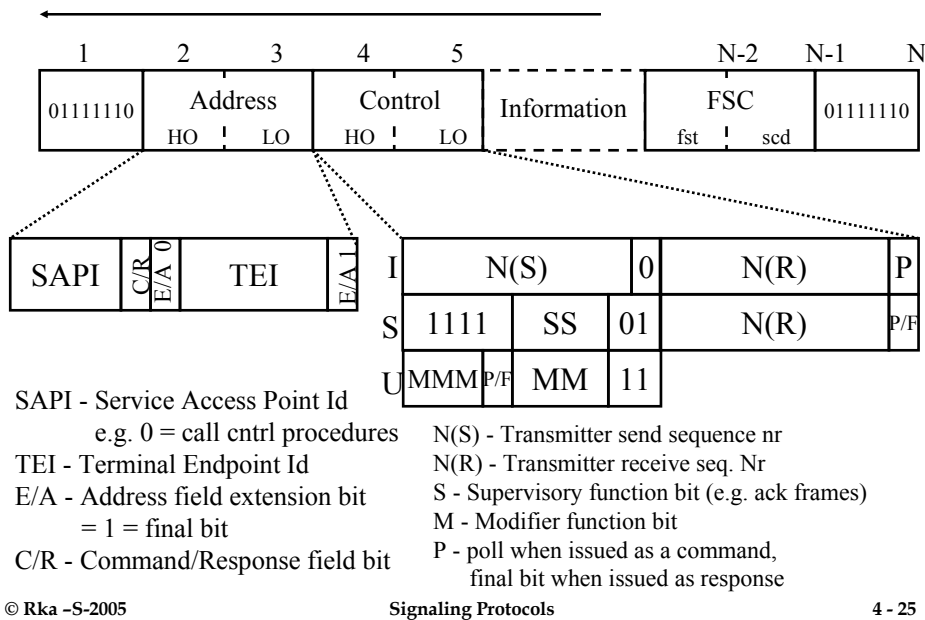

Q.921 - LAPD

- ✓ Point-to-point link connections, multi-point connections - broadcast
- ✓ Initiation state - TEI values not yet chosen.
- ✓ Unnumbered Information = UI -frames are not acknowledged
 - › also broadcast (e.g. SETUP to B subscriber)
 - › faults recovery is left for the upper layers.
- ✓ Acknowledged mode - I - numbered frames
 - › fault recovery and flow control procedures supported on layer 2

DSS1 - Q.931 - signaling

- ✓ **Corresponds to layer 3 - network layer:**
 - › understands end-to-end addresses: E.164 telephone numbers
- ✓ **Can set up, control and release circuit switched calls.**
- ✓ **Supports also packet switched on-demand connections.**
- ✓ **Call identification is based on the *call reference* - and has nothing to do with e.g. the identity of the B-channel in use!**
- ✓ **Supports the functional and the stimulus (keypad) modes of signaling.**
- ✓ **User-to-user information transfer in signaling messages is also supported (charging is an issue).**

Functional and stimulus -modes

- | | |
|--|--|
| <ul style="list-style-type: none">✓ Functional<ul style="list-style-type: none">› Information is encoded in service specific information elements.› As a result, signaling becomes <i>service dependent</i>. A new service requires new programs both in the CPE and the exchange› Can be OK, if CPE = PBX› For phones would really require a JAVA -like automatic software download function. There is no such thing in ISDN! | <ul style="list-style-type: none">✓ Stimulus -mode:<ul style="list-style-type: none">› phone button pushes are carried in signaling as such,› Interpretation is the responsibility of the exchange› A new service requires new programs only in the network› The phone may have programmable soft keys to hide dialing sequences |
|--|--|

Q.931 -signaling call setup procedure

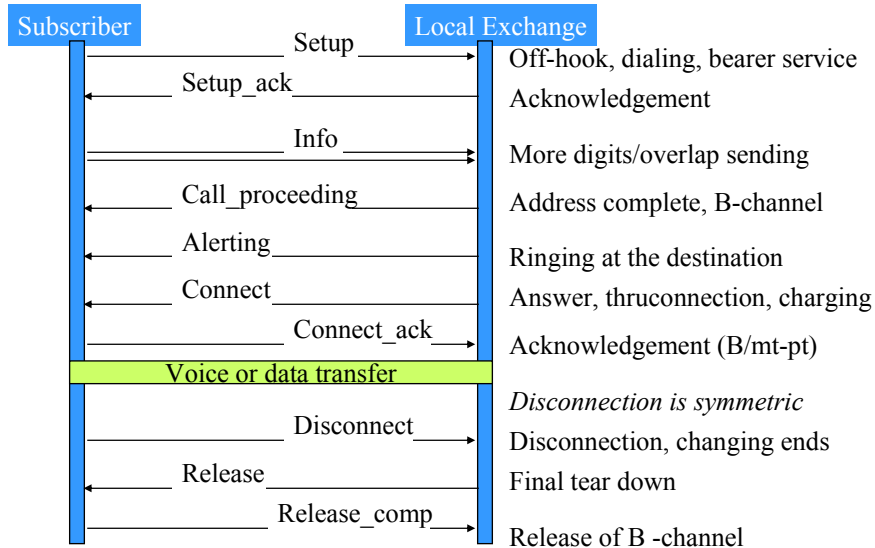

© Rka -S-2005

Signaling Protocols

NB: gives only one signaling scenario.

4 - 29

ISDN Summary

- ✓ Signaling and voice channel are both physically and logically separated (out-of-band, common channel + call reference).
- ✓ Any signaling info needed for services is supported or can be added.
- ✓ Q.931 signaling is service dependent, contains really information that is relevant on OSI-layers 3 - 7! New services require new programs in CPEs in case of functional mode. There is no mechanism for automatic software download to CPEs.
- ✓ Multi-point structure complicated the implementation significantly.
- ✓ Major consumer value added is in 2 x 64kbit/s bit rate. ISDN adoption is determined by home Internet use.
- ✓ ISDN specified a digital PBX access signaling for the first time. This has been widely adopted! ISDN signaling has been reused in many new signaling applications (V5, private PBX networks, IP-Telephony, conferencing, GSM etc.) So, ISDN (DSS1) is the mother of many modern signaling systems.

© Rka -S-2005

Signaling Protocols

4 - 30