

ISDN User Part - ISUP

- ✓ **ISUP - ISDN User Part**
 - › ISUP/TUP brief comparison
 - › ISUP additional features
- ✓ **Interworking of signaling systems**

ISUP is an international and national network signaling system for

- *call setup,*
- *supervision and*
- *release.*

*In addition it supports a wide range of ISDN supplementary services.
Used also in GSM and 3G.*

Separate versions for

- *International ISUP*
- *National ISUP in many countries (carry some legacy of older systems)*

Summary of course scope

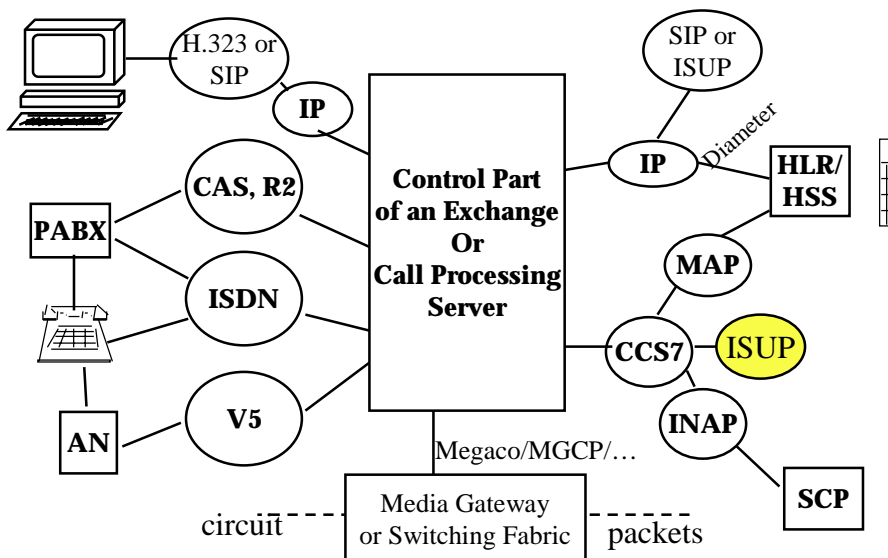

ISUP - ISDN User Part milestones

- TUP was specified before DSS1 ISDN user signaling during 1980's.
- ISUP2 specification was released after DSS 1.
- ISUP2 deployment in Finland started 1994.
- Core Network development path is CAS -> TUP ->ISUP.
- If TUP is already deployed, changing to ISUP is relatively easy by a software upgrade in exchanges, because MTP-infra is already in place.
- Recent development in ISUP:
 - ETSI additions of charging information messages into ISUP.
 - IETF (SIGTRAN) is specifying ISUP over IP

Why does the ISDN need ISUP instead of TUP?

Limitations of TUP compared to ISUP:



DSS 1 terminal compatibility information can not be transported in TUP,



User-to-User information is not specified in TUP signaling messages



ISDN Suspend/Resume is not supported in TUP,



TUP does not support all (Euro-)ISDN supplementary services
- call waiting, call hold ...



In TUP release is non-symmetric / in ISDN it is symmetric

Bearer services supported by ISUP are

- ✓ speech
- ✓ 64 kbit/s unrestricted (= transparent 64kbit/s)
- ✓ 3.1 and 7 kHz audio
- ✓ alternate speech / 64 kbit/s unrestricted
- ✓ alternate 64 kbit/s unrestricted / speech
- 2 x 64 kbit/s unrestricted
- 384 kbit/s unrestricted
- 1536 kbit/s unrestricted
- 1920 kbit/s unrestricted

ISUP offers extensions compared to TUP, but CSN is not able to compete with packet switching (the Internet) in the long run!

ISDN basic structures

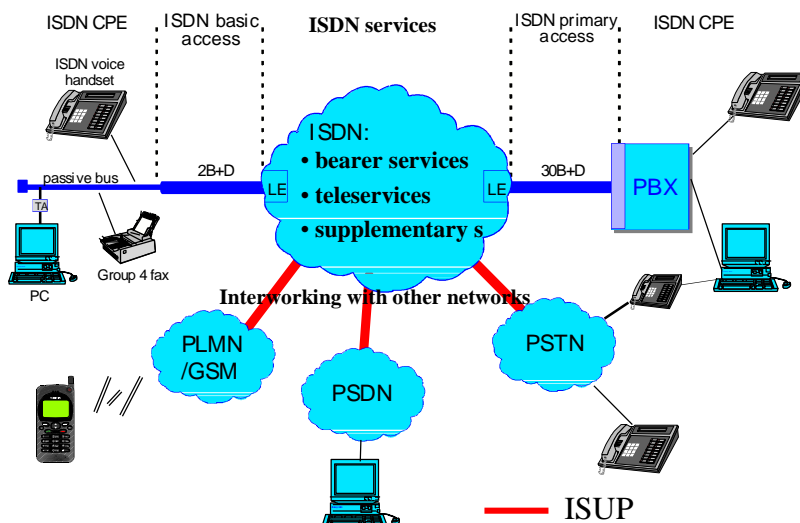

Basic structure of an ISUP message

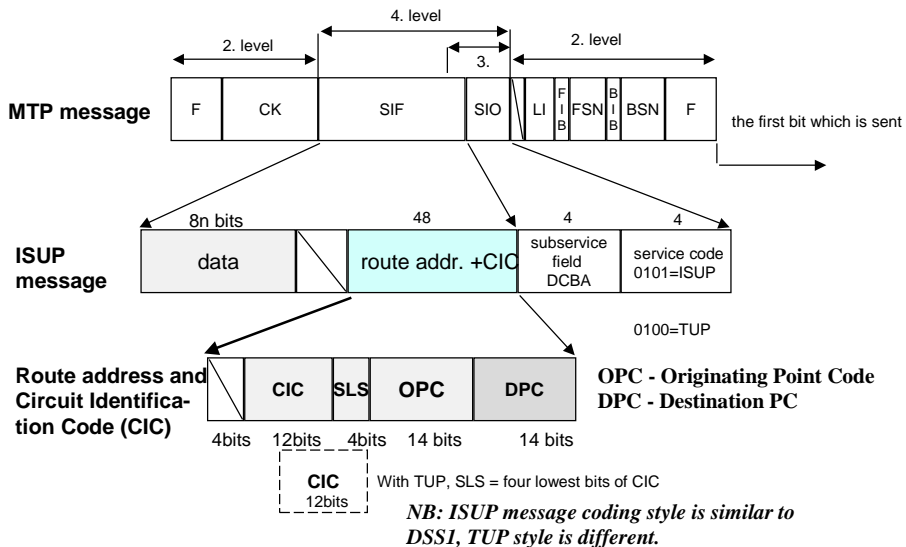

Call identification is based on a compulsory CIC and an optional (logical) call reference

- ✓ Call reference is recommended only for national use.
- ✓ $n \times 64\text{ kbit/s}$ connections are always built using consecutive timeslots, thus one CIC is enough.
 - $n \times 64\text{ kbit/s}$ -connection is identified using the smallest CIC among the time-slots.
- ✓ CIC binds the user information channel (voice or data) and signaling together. One can not exist without the other
 - --> one result is that in IN a special standardised Basic Call State Model is needed. The BCSM is used to track the state of the resources in an SSP (service switching point) while an SCP (service control point) processes additional features.
 - Binding to CIC is also an issue when Interworking with IP Telephony systems because in IP telephony willingness to participate is established prior to any voice path activity.

A successful ISUP call (calling subscriber initiates release)

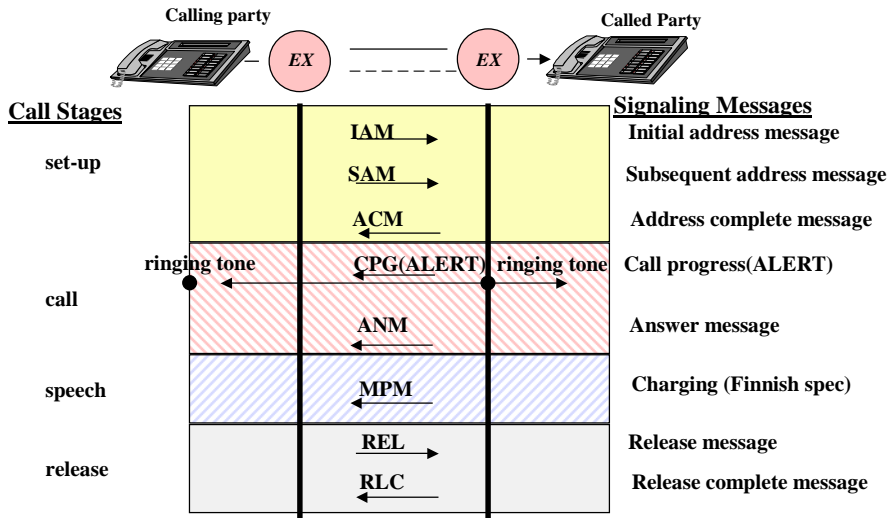

© Rka/ -S-2004

Signaling Protocols

6 - 9

Sample ISUP messages

- ✓ IAM: will carry bearer service identification, all digits if dialling sequence is like in GSM, may carry some leading digits in case of PSTN like dialling sequence.
- ✓ SAM: sending of SAMs is dependent whether dialling plan has a fixed nrof digits for the leading digits sent in IAM (or that generated the IAM) or the dialling plan allows variable nrof digit per destination. Variable length numbers go hand in hand with DDI (direct dialling in for PABXs). Routing files may have instructions when to send SAMs and what kind
- ✓ ACM tells that no more digits are needed nor will be processed
- ✓ ANM tells that B-party has answered and charging can begin.
- ✓ Tariff information can be carried in Charging messages. Eases tariff maintenance and supports a more dynamic market place with competition between providers.

© Rka/ -S-2004

Signaling Protocols

6 - 10

ISUP circuit supervision messages --> circuits and 2M connections can be taken into use and from use in a managed way.

- RSC Reset circuit
- BLO Blocking
- BLA Blocking acknowledgement
- UBL Unblocking
- UBA Unblocking acknowledgement

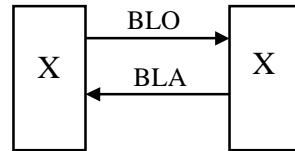

Can not place calls on cic def in BLO

- EHL End-of-hold (*)
- EHA End-of-hold acknowledgement (*)
- OLM Overload (*)
- UCIC Unequipped circuit identification code (*)

(*) For national use

Forward COMPATIBILITY is ensured from the 1992 release onwards

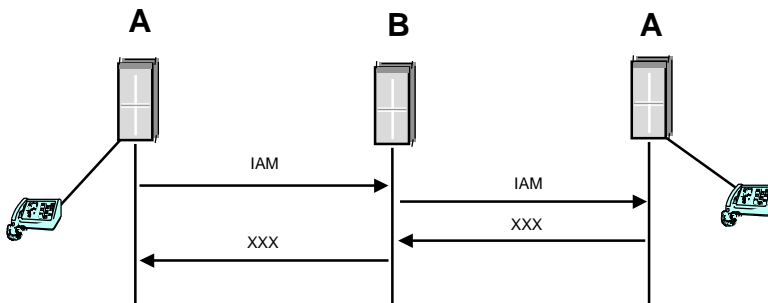

MESSAGE COMPATIBILITY INFO
 - TRANSIT AT INTERMEDIATE EXCHANGE INDICATOR,
 - RELEASE CALL INDICATOR,
 - SEND NOTIFICATION INDICATOR (CONF),
 - DISCARD MESSAGE INDICATOR,
 - PASS ON NOT POSSIBLE INDICATOR,
 - ...

A message carries a rule what to do if something unknown=new in the msg

ISUP message coding supports ISUP software upgrades - old and new version can talk to each other!

Version compatibility rules: the following should not be changed:

- ✓ Protocol procedures, messages, information elements, coding, except to correct an error in the protocol.
 - ✓ Semantics of existing info elements.
 - ✓ Formatting and coding rules
 - ✓ Adding new parameters into mandatory part of Messages, Optional part can be extended.
 - ✓ Order of information items in an Information Element of variable length, new items can be added to the end of the IE.
 - ✓ Information item value =“all 0” == non-significant value.
- + **Fall-back and other compatibility procedures.**

Rules apply from ISUP'92.

Calling Line Identification Presentation - CLIP - is a supplementary service supported by ISUP

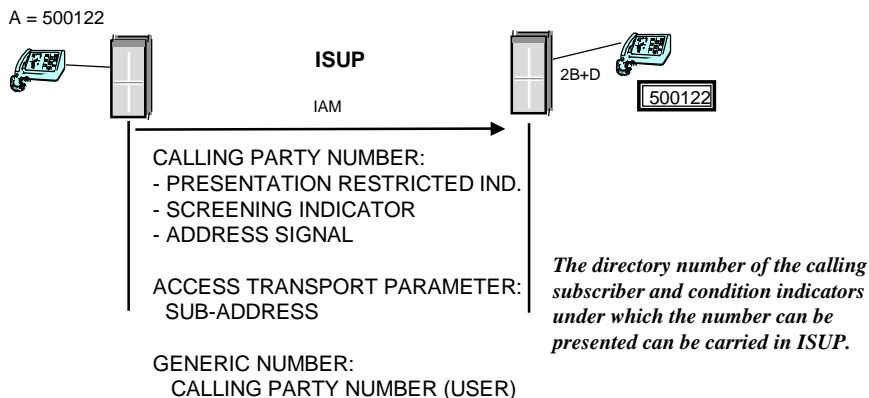

Calling Line Identification Presentation Restriction - CLIR - is a pair to CLIP

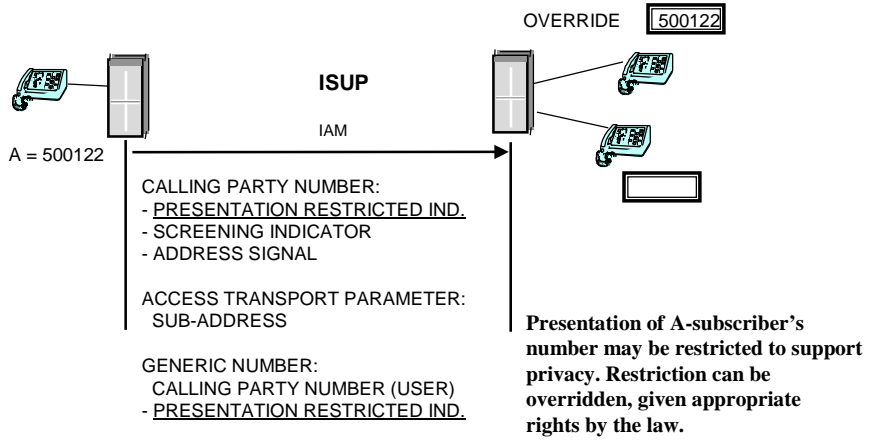

Connected Line Identification Presentation -COLP - is a mirror image to CLIP

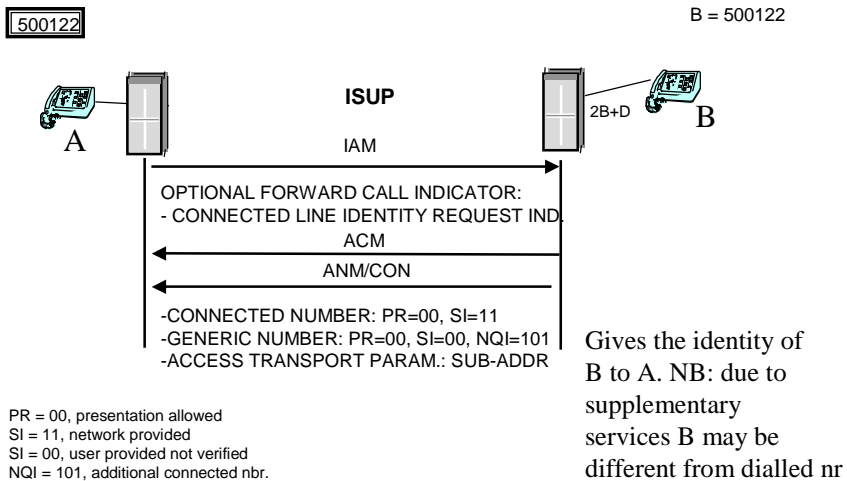

Connected Line Identification Presentation Restriction - COLR - is the pair to COLP

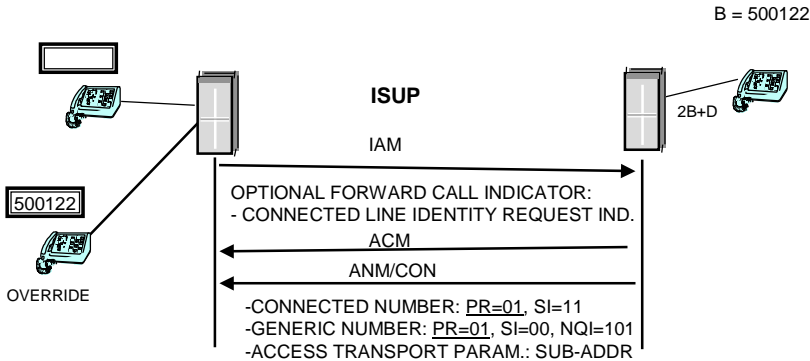

PR = 01, presentation restricted
 SI = 11, network provided
 SI = 00, user provided not verified
 NQI = 101, additional connected nbr.

User to User Signalling 1 - UUS1 - allows transporting user provided information over CCS7 network

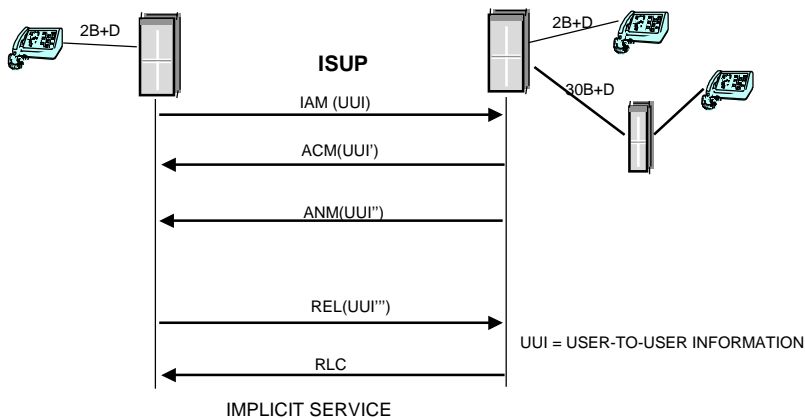

→ Application level info can be made a precondition of setting up a call.

Terminal Portability (TP) - ISDN allows interrupting a call and resuming it even from a different phone or phone line..

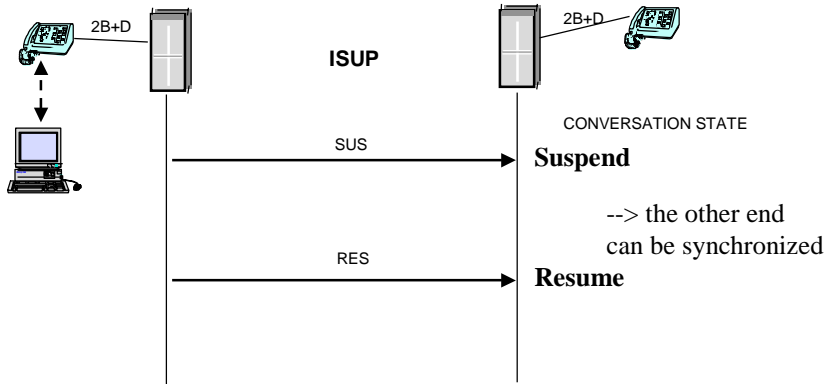

Call Forwarding No Reply - CFNR - automatically forwards an incoming call to C-number

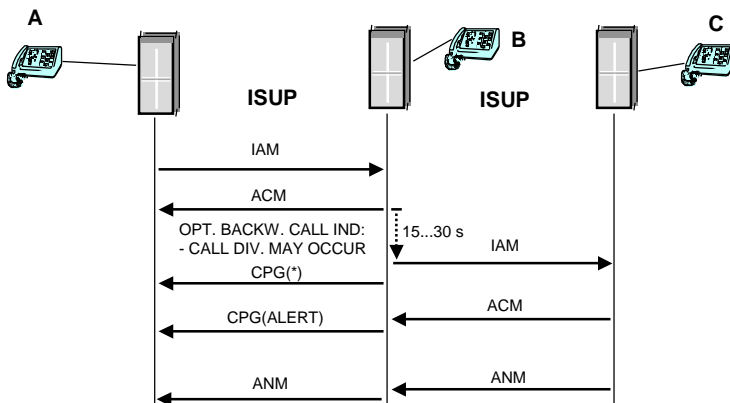

(*) CALL DIV. INFO, REDIR. NBR., GENERIC NOTIF.

Call from B to C is paid by B.

About supplementary services

- ✓ **Can be divided into A subscriber services and B subscriber services.**
 - › service data and control reside either at A or B
 - › not all supplementary services require support from network signaling
 - › some services can be implemented in the terminal or in the network
- ✓ **Other examples**
 - › Call transfer
 - › Call completion to busy subscriber (call back when free)
 - › Call forwarding unconditional,
 - › Call forwarding on busy
 - › Many PABX –type services: call pick-up ...
- ✓ **Business wise: how important are these supplementary services? (very important when buying decisions are made but not widely used by subscribers...)**

Signaling interworking occurs in an exchange if two legs of the call are managed using different signaling systems

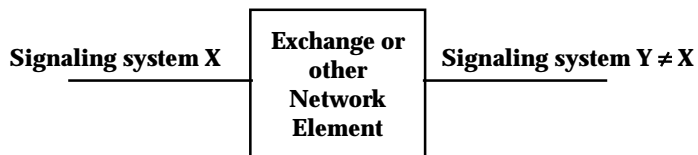

- ✓ **Interworking of signaling systems**
- ✓ **Also we talk about signaling interworking if two peer exchanges are manufactured by different vendors (interworking of different implementations)**
- ✓ **cmp. compatibility**

DSS1 / ISUP -interworking

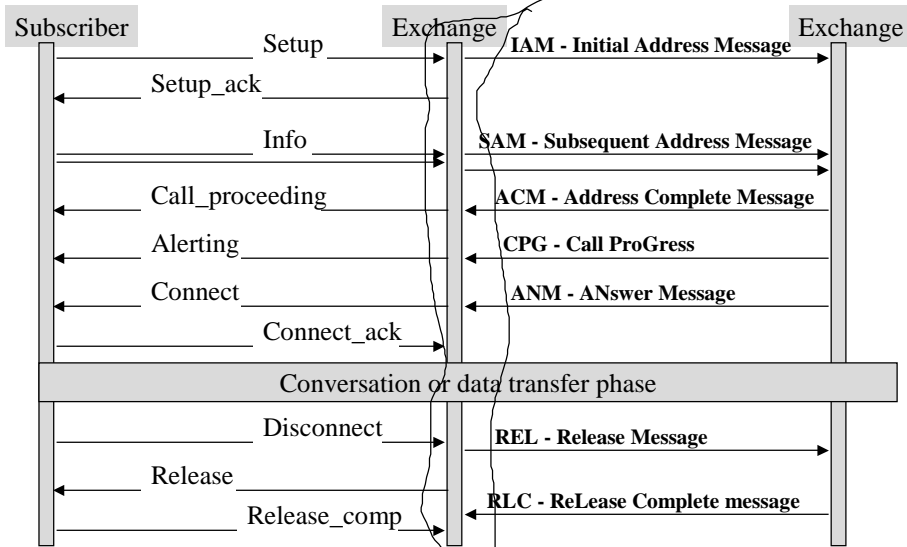

© Rka/ -S-2004

Signaling Protocols

6 - 23

Each signaling system has its own set of signals of information elements -> in interworking almost always some info is lost.

- To ensure smooth interworking, functioning need to be carefully specified. If we have n signaling systems, there are n^2 interworking cases!
- Standardization bodies use two methods for the specification of interworking:
 - For Channel Associated signaling: event based FITE/BITE -method.
 - For message based signaling: layer oriented method.

© Rka/ -S-2004

Signaling Protocols

6 - 24

Event based interworking specification method

FITE - Forward Interworking Telephone Event
 BITE - Backward Interworking Telephone Event
 SPITE - Switching Processing Interface Telephone Event - internal to an exchange.

} Between signaling systems.

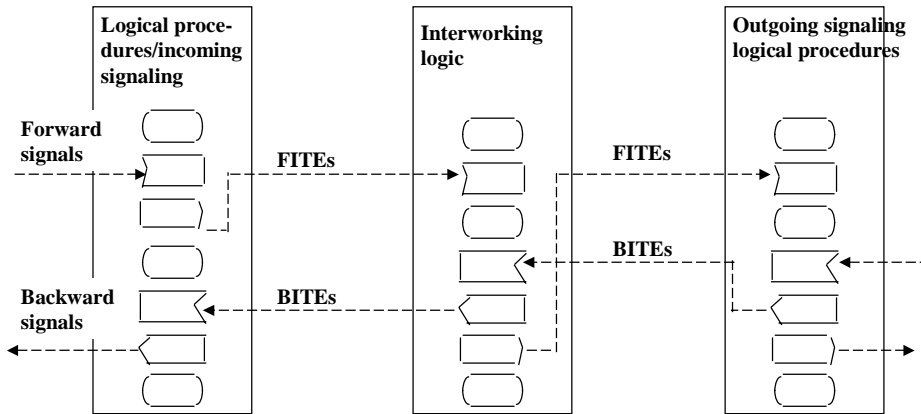

Incoming and outgoing signaling systems are analyzed only to the extent necessary for the specification of interworking. Logic is given using SDL.

Layer oriented interworking specification

Primitives carry the information between layers

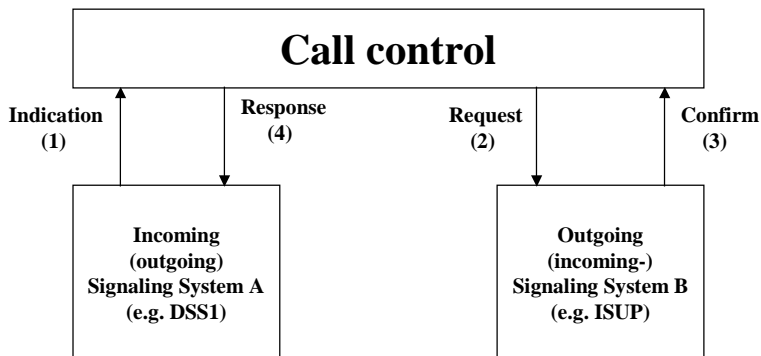

Numerot ilmaisevat primitiivien järjestystä

Signaling flow is described in more detail:

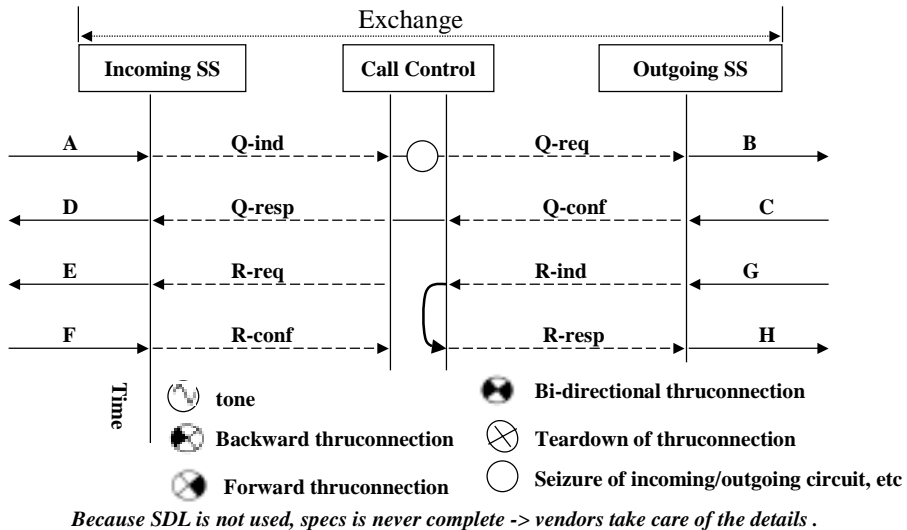

Latest development of ISUP

1. ISDN charging protocol to transport tariff and billing info
 - The Finnish network has traditionally carried charging messages. In most other countries the originating exchange needs to know all tariffs in the world.
 - Reflect the difference between monopoly and competitive markets
 - ETSI specifies messages between charging points to transport information about additional tariffs on a call by call basis:
 - Final tariff may be composed of many parts
 - tariff info is maintained by the party, who wants to earn the money.
 - Makes easier to apply dynamic tariffs.

ISUP2 carries charging info

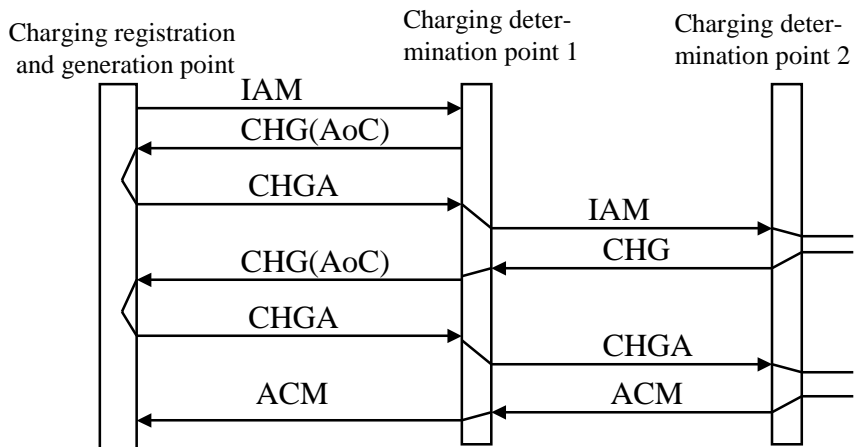

In charging generation point, info can be processed into a new form,
The registration point produces a CDR- call detail record

ISUP - more ongoing development

2. ISUP-over-IP for IP-telephony networks

- e.g. In Finland in pilot use although the specs is not ready
- SIGTRAN group in IETF

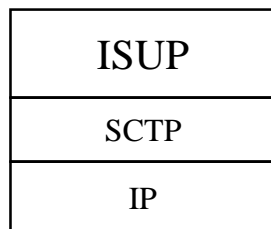

Stream Control Transport Protocol
= transport protocol for e.g. signaling
modified from TCP

- SCTP/IP replaces MTP + (SCCP)
(SCCP =?, may survive.)

We will talk about SIGTRAN later on this course.