

# S38.115 Signaling Protocols

## ✓ Modeling of signaling systems

- ✓ Signaling flow charts
- ✓ (Extended) Finite state machines

## ✓ Subscriber signaling

- ✓ Impulse code
- ✓ Multifrequency code (DTMF - dual tone multifrequency)

## ✓ Trunk signaling

- ✓ Register signaling
- ✓ Line signaling

## ✓ R2 signaling system

PSTN

## Summary of course scope

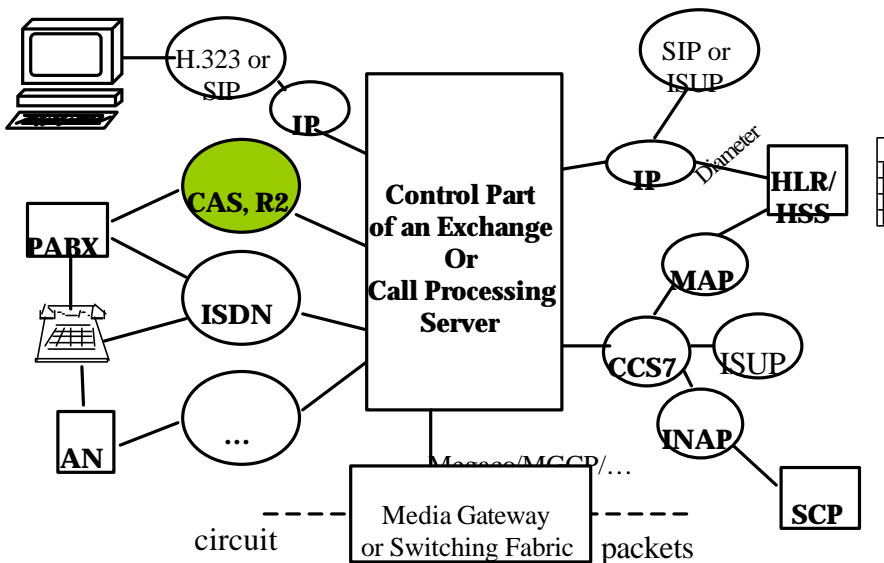

## Signaling Flow Chart illustrates the main events

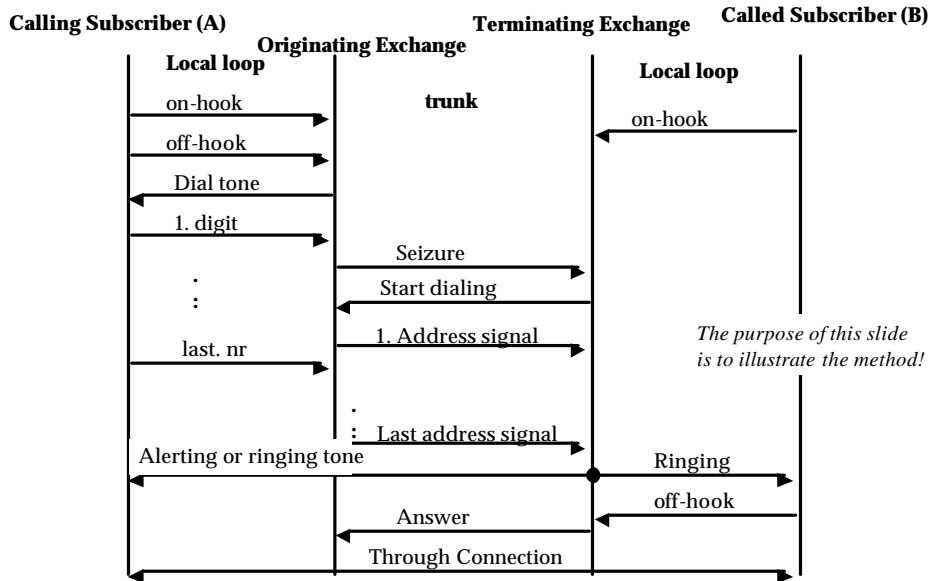

## Signaling Flow Chart example cont...

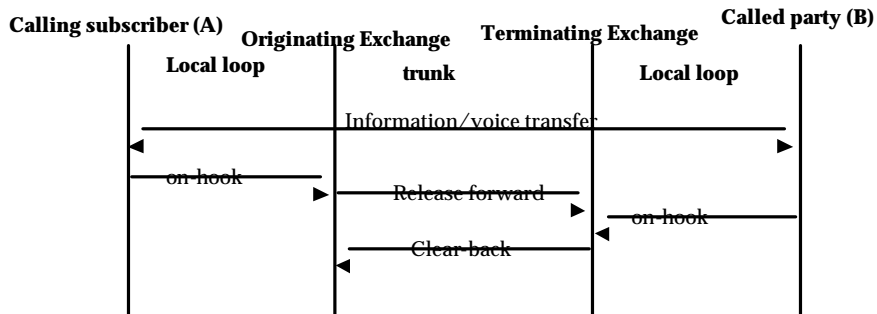

- NB: Exchanges must signal both in forward and backward direction on incoming and on outgoing side simultaneously.
- Incoming and Outgoing signaling can be separated, so can
- Incoming Call Control and Outgoing Call control.

## Extended Finite State Machine is very suitable for modeling signaling senders and receivers.

Algebraic representation

$\langle s_0, I, O, U, S, f_s, f_o, f_u \rangle$

$s_0$  - initial state  
 $I$  - set of incoming signals  
 $O$  - set of outgoing signals  
 $S$  - Set of States  
 $U$  - Set of values of state variables  
 $f_s : (S \times I \times U) \rightarrow S$  - next state  
 $f_o : (S \times S) \rightarrow O$  - outgoing signal  
 $f_u : (S \times S) \rightarrow u_s \subset U$  - new values of state variables

$I_s \subset I$  - set of possible incoming signals in state  $s$

$i \in I_s$  can be unique in the signaling system or context dependent.

## Graphical representation of an FSM

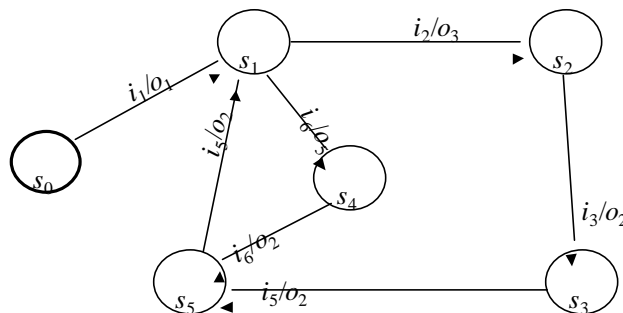

FSM - Finite State Machine

The use of FSMs is well known also in computer languages e.g. for lexical analysis. In this course it turns out that all most important real time programs in a Switching System are FSMs or sets of FSMs.

# SDL representation of an FSM

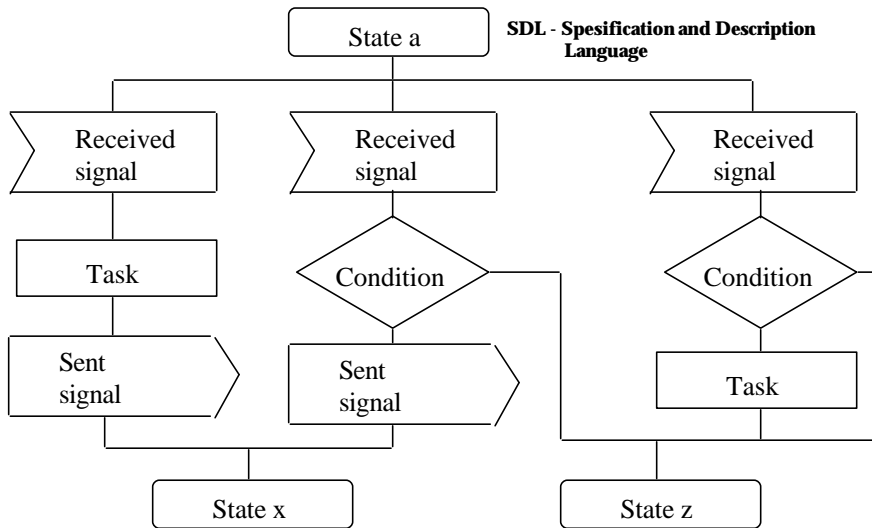

# A subscriber as an SDL -state machine

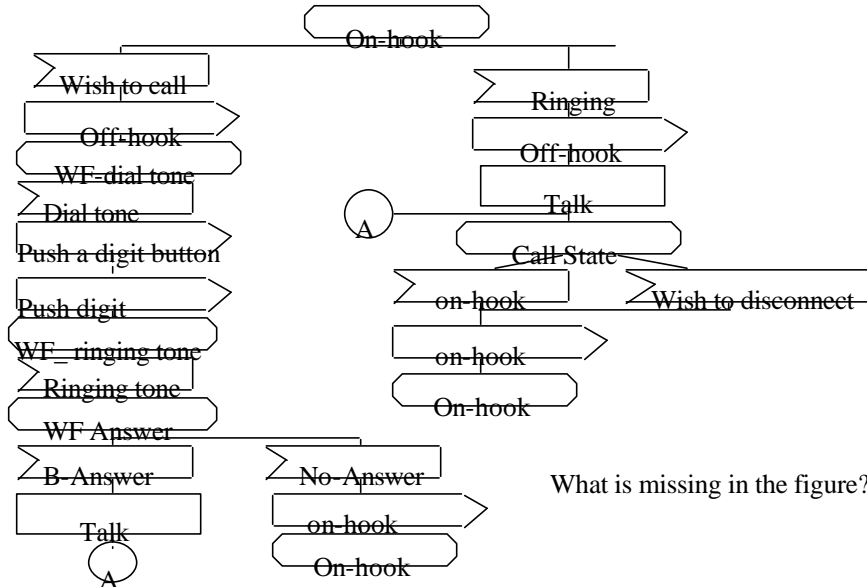

What is missing in the figure??

## *You can model the world like this*

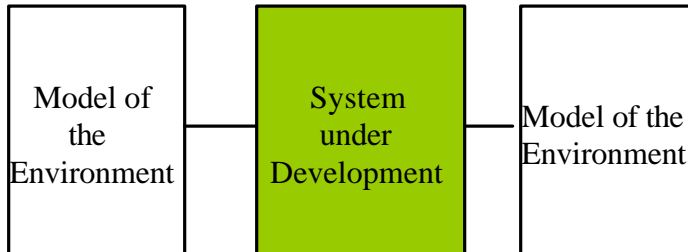

- Can use verification tools to debug your design.

## *How are these methods used in implementing signaling systems?*

- ✓ **Signaling Flows may be provided in the protocol specification for all main sequences of events**
  - if not, they are drawn by the implementor for example by measuring an existing historic system with no valid documentation
- ✓ **SDLs are drafted for the signaling system independent of the implementation environment**
- ✓ **The system independent SDLs are used as a starting point for the implementation specification for the target implementation (computer or system) environment**
  - details are added gradually. E.g. the execution model is taken into account.

This approach is one example. More ad hoc approach is also possible but I do not recommend it.

## *Execution models of FSM programs*

```
Initialisation
Do Forever
    Receive Message
    A <- Branch (State, (Secondary state,) Message)
    Execute Transition (A)
Od
```

- Execution model 1: Complete the current Transition always before starting anything else (non-pre-emptive scheduling)
- Execution model 2: A Transition can be interrupted at any time if there is a new task with higher priority (pre-emptive scheduling)
- Depending on implementation a Transition may or may not contain a new (secondary) Receive Message Statement.

## *Table representation of an FSM*

Current State	Next State		
	Incoming signal		
	$i_0$	$i_1$	$i_2$
$s_0$	$s_1$	$s_0$	$s_0$
$s_1$	$s_1$	$s_2$	$s_1$
$s_2$			

## ***Signaling is used to allocate network resources for the call in a CSN***

- ✓ Signaling carries control information from the end user and another exchange. The info implies that certain circuits and devices in the exchange need to change state.
- ✓ Call state includes records on all resources allocated for the call (time slots, signal receivers and senders, memory, processes, records etc). It is vital that all resources are released when the call is released.
- ✓ Signals can be decadic impulses, voice band tones or binary signals or messages transported in a packet network.
- ✓ Signals transferred on a local loop between a terminal and the local exchange form *subscriber signaling*.
- ✓ When two exchanges send and receive signals we talk about *trunk signaling* (inter-exchange signaling, inter-carrier signaling etc...).

## ***A Signaling System***

- ✓ **A signaling system is a given  $\langle s_0, I, O, U, S, f_s, f_o, f_u \rangle$ .**
- ✓ **One of the key structural properties of a signaling system is, *how signaling information is associated with the voice path.***
- ✓ **In the PSTN, depending on penetration of digital exchanges, the following types of signaling are used:**

<b>Network</b>	<b>Loop signaling</b>	<b>Trunk signaling</b>
Analogue	Pulse- and multi-frequency	Channel Associated
Digital	Pulse- and multi-frequency	Common Channel
ISDN	DSS1 (Q.920...Q.931) (digital sign systems nr 1)	Common Channel Signaling (CCS #7)

## *Subscriber or loop signaling*

- ✓ The terminal (a phone) sends information to the network in either rotary impulses or in Dual-Tone-Multi-frequency (DTMF-) signals.
- ✓ A DTMF-signal has two frequencies out of six.
- ✓ Such Frequencies are used that they have no harmonic components with the other frequencies:
  - Good immunity to voice signals (incl. whistling) is achieved
  - No interference between dial tone and the first digit
  - Impact of local loop is minimized (attenuation is proportional to square root of frequency)

## *DTMF-signals are created with a push button phone*

	1209Hz	1336Hz	1447Hz	1633Hz
697Hz	<b>1</b>	<b>2</b>	<b>3</b>	<b>A</b>
770Hz	<b>4</b>	<b>5</b>	<b>6</b>	<b>B</b>
852Hz	<b>7</b>	<b>8</b>	<b>9</b>	<b>C</b>
941Hz	<b>*</b>	<b>0</b>	<b>#</b>	<b>D</b>

Pushing a button creates a continuous signal with 2 frequencies



## *Impulse signals are created by the rotary disk*

- ✓ Impulses are created by cutting and reconnecting the local loop (current on and off).
- ✓ On/off states in an impulse are 40 and 60 ms.
- ✓ The number of such impulses is a telephony signal, e.g. digit 3.
- ✓ Between two signals an interval of 400-800 ms is used to separate signals.
- ✓ Signals are created on the backward rotation of the disk

## *Responses to the terminal*

- ✓ Terminal receives the following indications as responses to the signals it has sent:

Semantics	Frequency	Timing
Dial tone	425 Hz	continuous
Ringing tone	425 Hz	1s on, 4s silence
Engaged/Busy	425 Hz	300 ms on, 300 ms off
Queueing	950 Hz	650 ms
	950 Hz	325 ms
	1400 Hz	1300 ms on, 2600 ms off

In terms of modelling the signaling flow, tones are like signals. However, tones are transported in the voice band and intermediate exchanges usually do not see them!

## ***Call establishment procedure or signaling sets up*** the call between two parties across the network

- ✓ Trunk signaling can be divided into two phases: call set-up control or inter-register signaling and line signaling.
- ✓ In setting up a call, devices called *incoming and outgoing register* were used in earlier exchange types, thus register signaling.
- ✓ Call set up (register phase) ends in the *ringing state*, and devices seized for the call (such as registers) are released for use by other calls.

Incoming and outgoing registers were used in crossbar and relay exchanges. In digital exchanges the same functions are performed by programs. Allocating Register phase call processing and signaling to separate programs may save memory, but will make call control more difficult during the call. When computer memory became plentiful and ISDN emerged, the separating of register and line signaling phases lost its importance.

## ***Line signaling takes care of call supervision and tear-down (release)***

- ✓ Line signaling is used to control the state of line or channel specific equipment.
- ✓ Line signaling starts when the call has been set up and call routing has been performed.
- ✓ Line signaling supervises call tear-down and may also send charging information to a charging point (Finland).
- ✓ Call signaling ends with the release commands to exchange devices and circuits that the call was using.
- ✓ Another name: supervisory signaling.
- ✓ Often physically line signals look quite different from register signals.

## *Number Analysis links the information received from signaling to call routing*

- ✓ **Analysis result is determined by**
  - Dialed digits ( from call set up signaling)
  - Incoming circuit group,
  - Origin or subscriber category (e.g. operator - see R2 group II)
- ✓ **Analysis may return**
  - a set of routing alternatives
  - an instruction to perform number translation (e.g. 0800-numbers):  
In this case, the analysis may need to be repeated
- ✓ **Analysis trees are built by MML-commands issued by the operator based on a route plan**

## *An example of route descriptions*

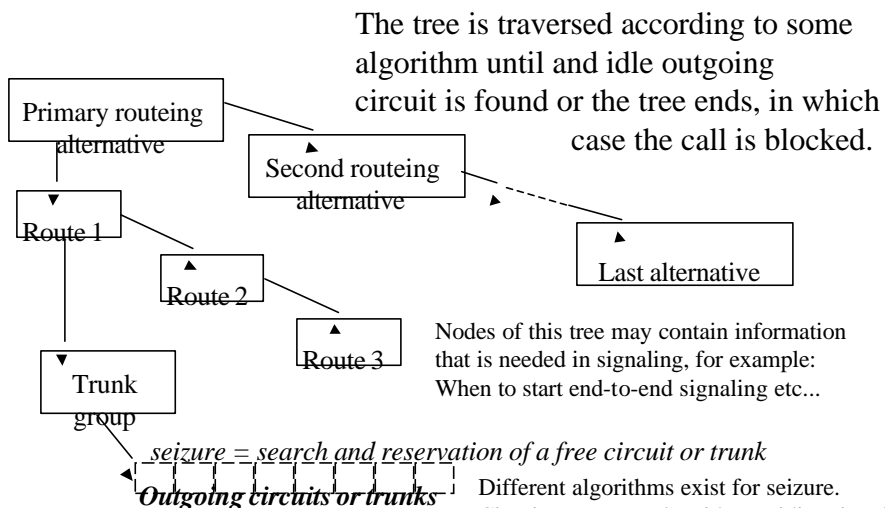

## *Some Signals used in trunk signaling*

Line/Set-up	Signal	Direction
L	seizing signal	--> (forward)
L	seizing-acknowledgement	<-- (backward)
S	request for an address signal	<--
S	address signal	-->
S	congestion signals	<--
S	address complete signals	<--
S	subscriber free (charge)	<--
S	subscriber free (no charge)	<--
S	subscriber line busy	<--
L	answer signal	<--
L	charging pulse	<--
L	clear-back signal	<--
L	release-guard signal	<--
L	clear-forward	-->
L	blocking	<--
L	remove blocking	<--

## *Channel Associated Signaling (CAS)*

- ✓ A category of trunk signaling between exchanges
- ✓ Is originally based on properties of electrical circuits typical in crossbar and relay exchanges.
- ✓ In Channel Associated signaling the association of the voice path with the signal path may be based on space or frequency or time division multiplexing.
  - **Space division:** each voice copper pair is associated with a signaling copper pair. Wastes a lot of copper, therefore, different multiplexing schemes have been developed.
  - **In frequency and time division multiplexing (TDM),** the location of the signaling channel determines the associated voice channel. PCM (pulse code multiplexing) is an example of a TDM system, that uses *time-slot 16* to carry signaling of the voice channels. A multi-frame structure is used to establish the association between the voice and the signaling channels.

## ***R2 and N2***

- ✓ Among CAS systems, in Finland, the most widely spread is probably R2. A CAS system called N2, developed by Siemens was also widely used especially by the Helsinki Telephone Company.
- ✓ R2 is the most powerful among analogue CAS systems and was originally specified by ITU-T and elaborated by national standardization.
- ✓ R2 is a *forward and backward compelled* signaling system **for call establishment**. Sender continues sending a signal until it sees an acknowledgement signal from the the other end. This ensures reliable and fast operation.
- ✓ Each R2 signal is a continuous signal of two voice band frequencies on the voice path. R2 frequencies are not the same as DTMF that are used in the local loop.

## ***R2 is a call establishment signaling system***

- ✓ Call establishment signals are sent in-band. In-band means using the voice path for signaling (subscribers can not talk at the same time!)
- ✓ Originally, R2 was specified for trunk signaling = I.e. between public network exchanges in analogue PSTN
- ✓ Later digital R2 appeared (analogue signals are represented in a digital form but the signals are basically the same)
- ✓ Later R2 was adopted for PABXs. Direct Dialling In (DDI) can be implemented for PABX subscribers using R2. This use has survived the longest.

## *Compelled signaling method*

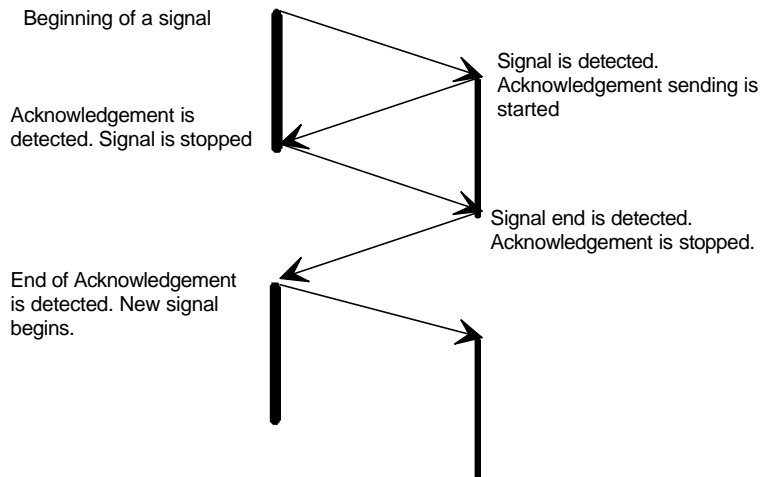

## *R2 and carriage of signals*

- ✓ R2 - system is based on end-to-end signaling. Intermediate exchanges just pick the information they need for routing the call, then they through connect the voice path and the rest of the signals can travel transparently onwards.
- ✓ R2 uses MF -coding, in which a signal is a combination of two voice band frequencies. Both forward and backward directions have their own set of six frequencies producing 15 possible signals in both directions.
  - R2 is not the same as DTMF: different frequencies and different semantics of signals. Similar physical representation of signals.
- ✓ These signals are grouped into two subgroups (I.e. each physical signal is used twice!) the use of which is controlled by the receiving end.

## *'Forward'-signals*

Signal	Group I	Group II
1	1	Ordinary subscriber
2	2	Subscriber with priority
3	3	Test call
4	4	Coin box
5	5	Operator
6	6	Data transmission call
7	7	Ordinary subscriber
8	8	Data transmission call
9	9	Priority extension
10	0	Operator
11	Special serv operator	Forwarded call
12	Negative ack	National signal
13	Test equipment	National signal
14	Network Operator specific	National signal
15	End of pulsing	National signal

## *'Backward'-signals*

Signal	Group A	Group B
1	Send next digit	subscriber line free
2	Repeat last but one address signal	Send special info tone
3	<b>Hop to receiving Group B signals</b>	subscriber line busy
4	Congestion in national network	Congestion
5	<b>Send A-subscriber category</b>	unallocated number
6	Connect to voice path	subscriber line free, charge
7	Repeat number n - 2	subscriber line free, no charge
8	Repeat number n - 3	subscriber line out of order
9	Send country code of A-subs	reroute to operator
10	Network Operator Specific	subscriber number changed

NB: Because of many variants, the exact signals may be different in different implementations. Naturally, both ends need to follow exactly the same implementation!

# PCM-frame structure

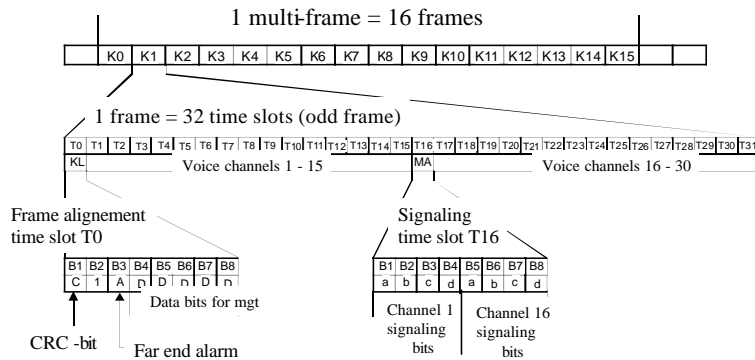

# Even numbered PCM 30-frame

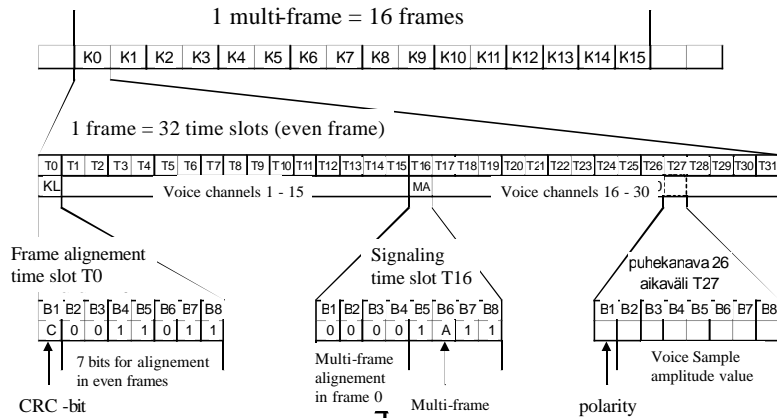

Applies only to K0, other even numbered, look at the previous slide



## *R2 - line signals*

- ✓ There are a number of variants of Line signaling for R2. A typical variant in Finland was (is) PCM -line signals. PCM -line signals are sent in timeslot 16 of the PCM -frame, so that the four bits (a, b, c, d) in the multi-frame dedicated to the corresponding voice channel are used as follows:

	Signal	a	b	c	d	a	b	c	d
	Idle	1	0	0	1	1	0	0	1
	Seizure	0	0	0	1	1	0	0	1
NB first abcd	Seizing ack	0	0	0	1	1	1	0	1
are forward bits	B-answer	0	0	0	1	0	1	0	1
second abcd are	Charging	0	0	0	1	1	0	0	1
backward bits	B off-hook	0	0	0	1	1	1	0	1
	Clear-back	0	0	0	1	0	0	0	1
	Clear-forward	1	0	0	1	1	1	0	1
	Clear forward	1	0	0	1	0	1	0	1
	Clear forward	1	0	0	1	0	0	0	1
	Blocking	1	0	0	1	1	1	0	1
	forward-transfer	0	1	0	1	1	1	0	1

## *Signaling after set-up of the call*

- ✓ It is typical in CAS systems that after setting up the call, terminals can not control the network in any way except initiate release.
- ✓ This is due to closing the signaling “connection” between the phone and the local exchange.
- ✓ Workaround methods have been developed. An LE can supervise the voice channel traffic and possible DTMF signals on the voice path or the line card can detect “polarity reversal”.
  - It must be possible to detect DTMF -signals among voice.
  - Polarity reversal can cause seizure of a register during a call. The register can reserve other signaling resources as needed.

## *Limitations of analogue signaling systems*

- ✓ **Only a small set of signals -> difficult to add new services.**
- ✓ **Context dependent semantics of signals --> modularization of programs is difficult.**
- ✓ **Signaling FSM controls the state of Exchange resources on a micro -level --> complex call control..**
- ✓ **Separate, e.g. DSPs are needed for signal detection and translation of R2 and DTMF signals.**
- ✓ **Voice channel and signaling channel have a fixed mapping. No signaling unless voice channel has been seized.**
- ✓ **Difficult to control the call after the setup.**
- ✓ **A lot of national and vendor specific variants.**