

# *Signaling Protocols - 3 cu*

**Lecturer: professor Raimo Kantola**  
**raimo.kantola@hut.fi, SE 323 ke 10-12**

**Assistants: Marcin Matuszewski**  
**(marcin@netlab.hut.fi)**

**Piia Pulkkinen (pulkkine@netlab.hut.fi)**

**Information: <http://www.netlab.hut.fi/opetus/s38115>**

*Rka - Raimo Kantola*

## *Contents and goal of the course*

- ✓ Introduction
- ✓ Signaling in PSTN and ISDN
- ✓ Signaling in GSM
- ✓ Signaling over IP in wireline networks
- ✓ Signaling in 3G networks (Rel 5...)
- ✓ Inter-working of signaling systems

Signaling will be analyzed on a functional level. Focus is on understanding advantages and drawbacks of widespread solutions

***Goal of the course: To understand signaling systems used in different networks.***

***→ to understand how networks interwork.***

***→ to understand the technology trend in signaling and call/session control***

***→ to understand how switching system functionality is inherited into a packet network environment***

## Why is signaling needed?

- ✓ To negotiate parameters of a session between two or more parties for a voice or voice+video call
  - to locate the other parties (one is the initiator)
  - to figure out whether the other party wishes to communicate
  - to agree technical parameters for communication
- ✓ In circuit networks to reserve, to keep track of all circuit resources for the call and to release the resources after the call
- ✓ In packet networks to reserve, keep track and release logical and physical resources for the session
  - Ports, holes in Firewalls, media processors, processes
  - To manage QoS

## Networking technology studies on 38.xxx courses

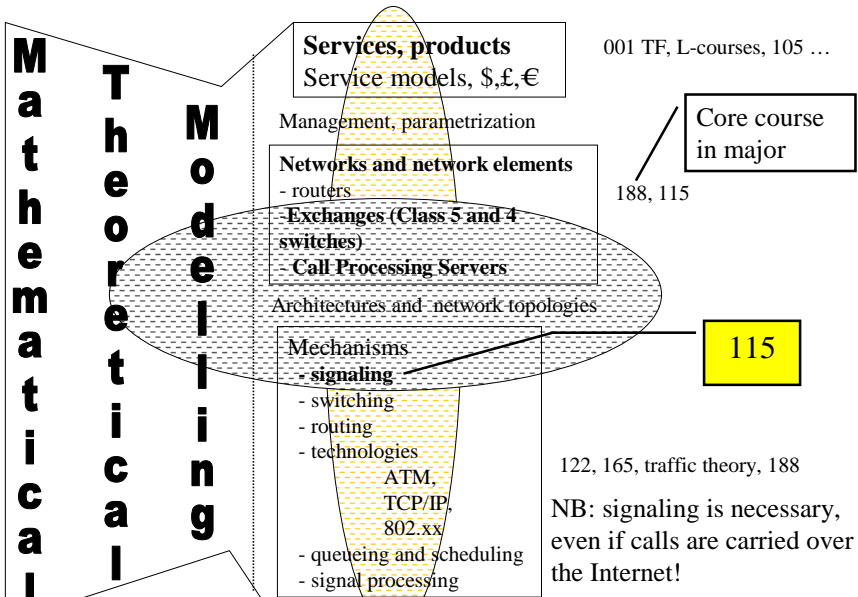

## ***Course Requirements***

- ✓ **These lecture notes**
- ✓ **Lectures are the best source for: Voip, TCAP, SCCP, MTP, MAP ...**
  - Do not make the mistake of thinking that you can pass the exam just by scanning through these slides! These slides have been produced to accompany oral lectures. After the lecture – these slides give you a hint of what is covered in this course. You are expected to dig the real content on the subject from other sources, in particular RFCs, 3GPP specs ...
- ✓ **RFCs, a few Internet drafts and [www.3gpp.org](http://www.3gpp.org) (for 3GPP specs)**
- ✓ **Exercises**
  - LME study package on signaling - exercise hours, SIP exercise sessions
  - A bit of calculus
- ✓ **Recommended additional reading:**
  - Richard Manterfield: *Telecommunication Signalling*;
  - Henry Sinnreich & Alan B.Johnson: *Internet Communications Using SIP*;
- ✓ **Grading**
  - Exercises max + 2 ...+4 points
  - No calculus (must earn at least 2p) => No admittance to Examination!!
  - Examination 30 points



## ***Telecommunication networks - Introduction***

- ✓ **Types of telecom networks**
- ✓ **Equipment types in telecom networks**
- ✓ **Hierarchy in telecom networks**
- ✓ **Switching Systems**
- ✓ **3G network**

## Communication networks can be divided into

- ✓ **Switched Telephone Networks (PSTN, ISDN, GSM ...)**
  - CSN (Circuit Switched Networks)
- ✓ **Computer (data) networks (x.25, Internet)**
- ✓ **Specialized or Professional Networks (PMR, Tetra ...)**
  - PMR - professional mobile radio
- ✓ **This course concentrates on telephony in circuit and packet networks.**

Signaling is processed by *Exchanges* in circuit networks and by *Signaling Servers* in packet networks.

Exchanges or Switching Systems are used in  
Public Switched Telephone Networks,  
Integrated Services Digital Networks,  
Cellular Networks and  
Specialized Networks

## Telephone Networks

- ✓ **Telephone networks can be divided into:**
  - Fixed Networks (wireline networks)
  - Mobile networks (cellular networks)
  - Public vs private (owned and operated by a corporation)
- ✓ **Growth of subscriber base takes place in cellular networks. In Fixed networks we see very little new deployment while total number of subscriptions is declining.**

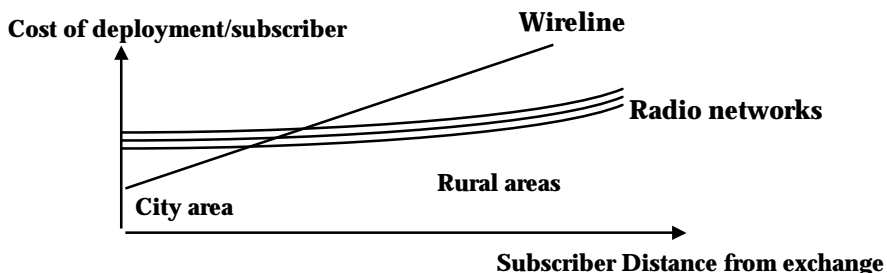

*Anyways: people seem to prefer to use a personal device!*

## World GSM subscriptions (millions)

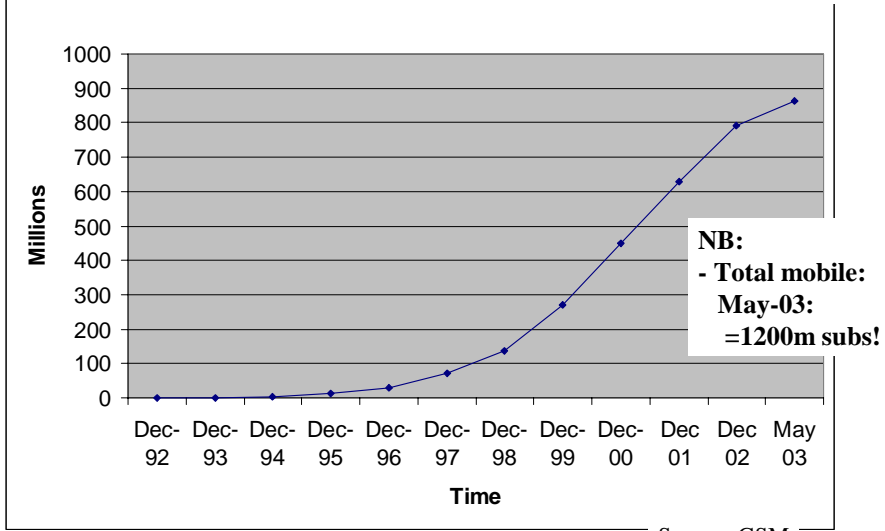

Source: GSM Association

## Total Wireless Subscribers

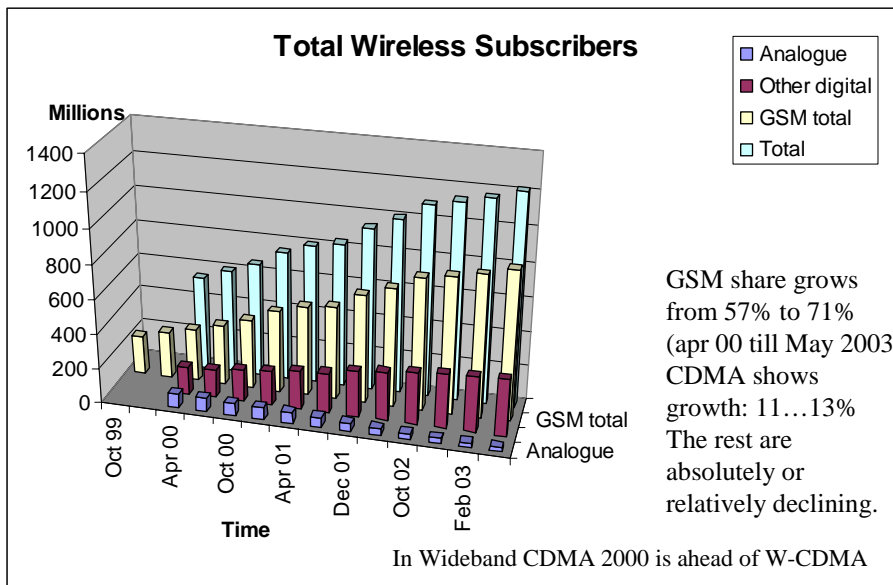

GSM share grows from 57% to 71% (apr 00 till May 2003)  
 CDMA shows growth: 11...13%  
 The rest are absolutely or relatively declining.

In Wideband CDMA 2000 is ahead of W-CDMA

Source: GSM Association

## *Computer (data) networks*

- ✓ A data network is any type of overlay network built for data traffic.
- ✓ Data networks are built using both permanent and switched connections.
- ✓ Protocols in Data Networks include X.25 ja Frame Relay (FR) and the Internet protocol.
- ✓ As these networks have become business critical, more dedicated connections are used.

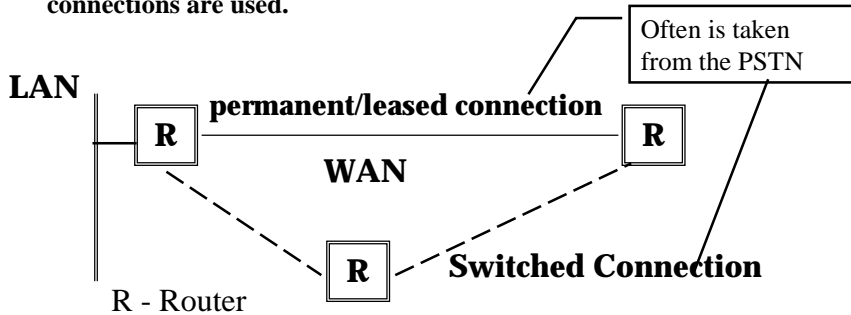

## *Capacity requirements for Telephony*

- ✓ **Case Finland:** Nrof users: 4 million.  
Nrof simultaneous users(?): 400 000  
Each call uses 64 kbit/s.

Assume all calls are carried on one link: Capacity requirement is:

$$400\,000 * 64\text{kbit/s two ways} = 25,6 \text{ Gbit/s.}$$

In practise 70% of calls are local. It follows that largest needed link capacities are < 10 Gbit/s (two ways).

IP network capacities:

- Current FUNET backbone links are 2,5 Gbit/s
- Latest FUNET upgrade (2004): 10 Gbit/s links!
- FUNET is supposed to serve only University people (300 000+)

## *Future of Fixed Telephone Network*

- ✓ **In Finland Nrof wireline subscribers is declining**
- ✓ **Nrof Broadband subscribers (ADSL + CaTV) is growing quickly**
- ✓ **Major operators have started offering VOIP to BB customers**
  - service is still poorly productized
- ✓ **It is a matter of pricing of GSM services to make PSTN/ISDN telephone service unattractive to users**
  - Corporations with a lot of buying power get GSM services on wholesale prices much lower than individual GSM customers. Even the lower priced GSM subscribers are profitable.



Scenarios for telephony:

- All voice goes wireless
- Wireless + wireline VOIP
- Wireless + VOIP as a feature of BB applications

A new phenomenon is peer-to-peer VOIP!

## *Specialized networks*

- ✓ **Specialized (professional) networks include:**
  - Military networks
  - Emergency services networks
  - Police networks
  - Company / Utilities communication networks (Railways, Gas and Electricity companies)
- ✓ **Widely varied technologies are used, some networks are overlay networks making use of PSTN resources, some are built using dedicated resources only.**
- ✓ **In Finland digital VIRVE, based on TETRA standard, is being built.**
- ✓ **Many types of (trunking) analogue radio networks exist (PMR - professional mobile radio).**

# *Equipment types in telecommunication networks*

✓ Based on type of usage, the equipment can be categorized into:

- Terminal equipment or CPE - customer premises equipment
- Exchanges (Switching Systems, Central Office in US)
- Call Processing Servers (e.g. 3G Multimedia System)
- Network Service Nodes (Value added Services, IN Services)
- Cross-connect Equipment
- Transmission Systems

**In terms of end- to-end service Cross-Connect and transmission equipment work on OSI layers 1 and 2. Nevertheless, they contain (management) software which can be on any OSI layer. In this course we just assume that these provide the necessary bitpipes.**

## *Key issues on each layer in the telecom network include*

OSI

7	Service Nodes	Intelligent Network Nodes, Voice Mail, ...	<ul style="list-style-type: none"> <li>• Differentiation, fast service creation and deployment, new service architectures</li> <li>• Interoperability, billing</li> </ul>
3	<b>Switching Systems</b>	<i>Exchanges, Concentrators, PBXs, Call Processing Servers</i>	<ul style="list-style-type: none"> <li>• Network design and dimensioning, routing/routeing,</li> <li>• <b>interworking (signaling)</b>, charging, <b>mobility</b></li> <li>• circuit and packet switching</li> <li>• <b>breakdown to connectivity and session layers</b></li> </ul>
2	Transmission Systems	PDH, SDH, WDM, xDSL, BSS/GSM, Radio links, Cross-connects ...	<ul style="list-style-type: none"> <li>• Coverage, large capacity (multiplexing),</li> <li>• Efficient use of radio band, radio network planning</li> </ul>
1	Circuit connections	Copper cable, cox, fiber, radio path, ...	<ul style="list-style-type: none"> <li>• Right of way, long life cycle, more efficient use of existing plant,</li> <li>• competition in the local loop/natural monopoly</li> </ul>

In Circuit networks signaling functionality resides in Switching Systems. In Packet networks (all IP, 3G) signaling resides on Session Layer.



## *Terminal Equipment*

- ✓ Terminal Equipment are owned and managed by the subscriber. They are used to communicate with another similar device across the network or with a Service Node in the network.
- ✓ Examples of terminal equipment types:
  - Phones, mobile phones, SIP phones, Office phones
  - Private (Automatic) Branch Exchange (PBX or PABX)
  - Modems
  - Router, bridge, LAN-switch, hub
  - Telemetric equipment
- ✓ A key assumption from the network point of view is whether TEs are Intelligent or not! This has a big impact on the choice of solutions on the switching or session layer in the network.
- ✓ Are connected to public networks using so called subscriber criteria.
- ✓ PABXs can form corporate networks. Use their own signaling methods such as QSIG, DPNSS (UK), also many proprietary signaling systems...

## *Exchanges implement switched services*

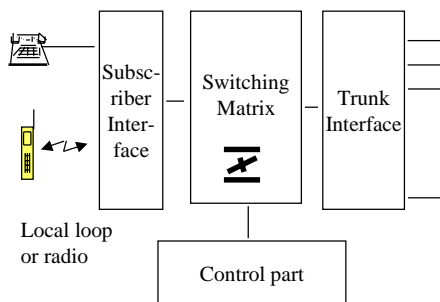

Software systems in the Control part:

- signaling and call control
- charging and statistics
- maintenance software

- ✓ Carriers of network intelligence.
- ✓ Routing of calls.
- ✓ Responsible for service level (grade of service)
- ✓ Giants of processor capacity and software ~ computers with many external connections and a lot of real-time parallel activity.
- ✓ Maintain signaling connections with subscribers, PABXs and with other public exchanges

## *When calls move to IP networks*

- ✓ **Connectivity and Session layers are separated**
  - On connectivity layer we have transmission and packet routing
  - On Session layer we have signaling and session control including routing of sessions
  - Call control and signaling server can reside anywhere in the IP network in relation to the caller and callee!
- ✓ **Call Processing Servers inherit most of the Exchange functionality of Circuit networks**
  - Session control (former call control)
  - Signaling
  - Charging (caller authentication etc)
- ✓ **Switching functionality of Exchanges is replaced by the packet routing infrastructure**

With static IP addresses peer-to-peer VOIP is a possibility = no network based servers are needed!

## *Service Nodes are computers connected to the edge of the telecom network*

- ✓ **Intelligent Network SCP - Service Control Point**
- ✓ **Voice mail systems**
- ✓ **Intelligent announcement device (intelligent peripheral or SRP - special resource point)**
- ✓ **Voice response system**

***By using Service Nodes operators aim to differentiate their service and thus compete not only on price.***

***Operators are looking for implementations that are switching system independent and have open software environment. Service Nodes may also control the set-up of calls.***

## *The purpose of Digital Cross-Connects is rearrangement of circuit connections*

- ✓ Work on OSI Layer 1 in the end-to-end view.
- ✓ Use cases: management of leased circuits, grooming of PCM -connections ( from partially filled PCMs to fully filled PCMs).
- ✓ A Digital Cross-Connect has a switching matrix and a light-weight control part that implements commands issued by a management system.
- ✓ The network management system is responsible for managing end-to-end circuit connections. The network management system issues commands to the cross connects to set up and tear down connections. The Cross connect may try to recover existing connections also in case of partial failures.

## *Transmission systems are used to optimize the use of physical circuits and to build coverage*

- ✓ Carry large bit streams across any distances.
- ✓ Are on OSI layer 1 in end-to-end view.
- ✓ Use optical or electronic components.
- ✓ E.g. PDH-systems ja SDH -systems
- ✓ An SDH-system needs more than one million source lines of software code ==> is a software product!
- ✓ Cost of transmitting a bit/km is declining fast.
- ✓ Trend is from synchronous to asynchronous and optical (SDH -> 10G Ethernet + Optical)
- ✓ Exchanges and transmission systems need to be compatible: they need a common specification on what does a *bit* and a *frame* look like on a circuit connection. They need a common understanding on *time* (*bit time, frame time*).

## *In business terms Communication Services can be broken down to Roles and Stakeholders*

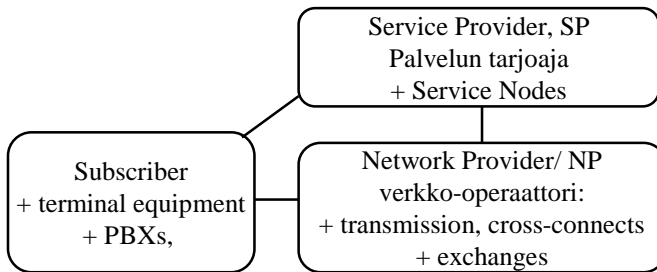

- This course analyses *signaling* which is the language used on the interfaces in the above figure.
- We will show that the real world signaling systems do not ideally match this business model.
- This has a significant impact on business boundaries: although NP business is considered dull and boring, NP is still the king! - I hope you will be able to argue on these matters after this course!

## *Telecommunication network hierarchy*

- ✓ ITU-T has specified a world wide hierarchy for the telecom network.
  - An end-to-end connection can have max 12 circuit connections out of which 4 can be international.
  - Addressing is hierarchical
- ✓ Exchange types
  - local exchange (Class 5 Switch in US)
  - originating/terminating exchange
  - transit exchange
  - long distance exchange
  - international exchange
- ✓ Traffic categories in exchanges
  - upstream, downstream
  - incoming, outgoing, internal, terminating, originating, transit

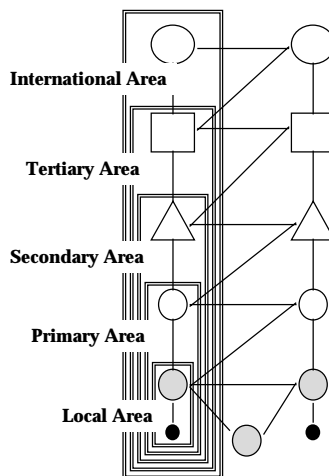

## Categories of traffic and exchanges

Upstream traffic goes up in the hierarchy.

Downstream traffic goes down in the hierarchy.

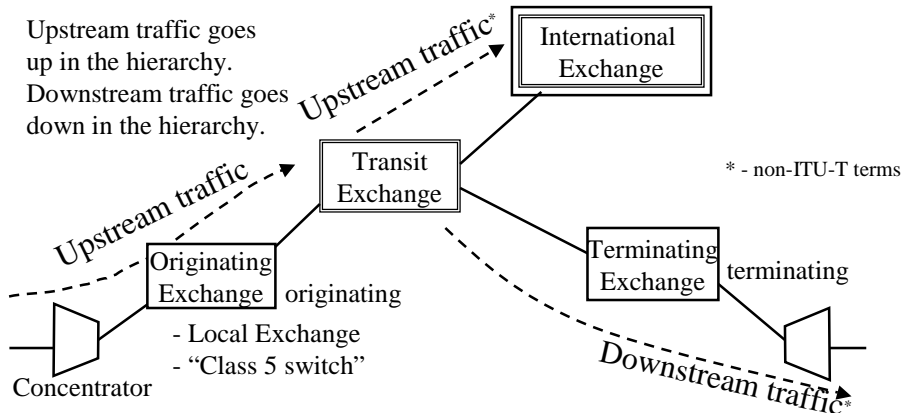

In Addition: *outgoing* traffic , incoming traffic (from the point of view of an exchange)  
 Internal traffic: from one subscriber connection to another in a local exchange,  
 terminating traffic: traffic that is terminated to subscribers at a terminating exchange,  
 transit traffic = from one network connection to another.

## Service Paradigm in a Circuit Switched Network

- ✓ **A permanent capacity circuit is set up on demand and sold to the customer. The network guarantees the quality of the circuit.**
  - After set-up customers can not disturb each other.
- ✓ **The customer can use the transfer capacity as best he/she can or as poorly as he/she can.**
- ✓ **The customer pays based on used network resources (usage based charging).**

Still: have look at your regular phone bill:  
 - there are lot of flat rate monthly charges!

***In the Connection Oriented Model connections are set up, and in the process the network translates global addresses to local***

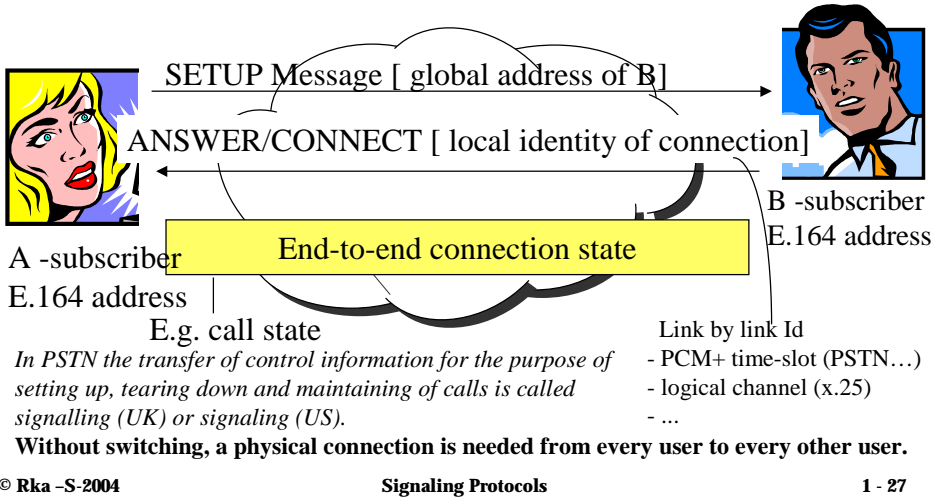

***IP network is connectionless: Caller and Callee must agree on parameters. Routing infra takes care of connectivity***

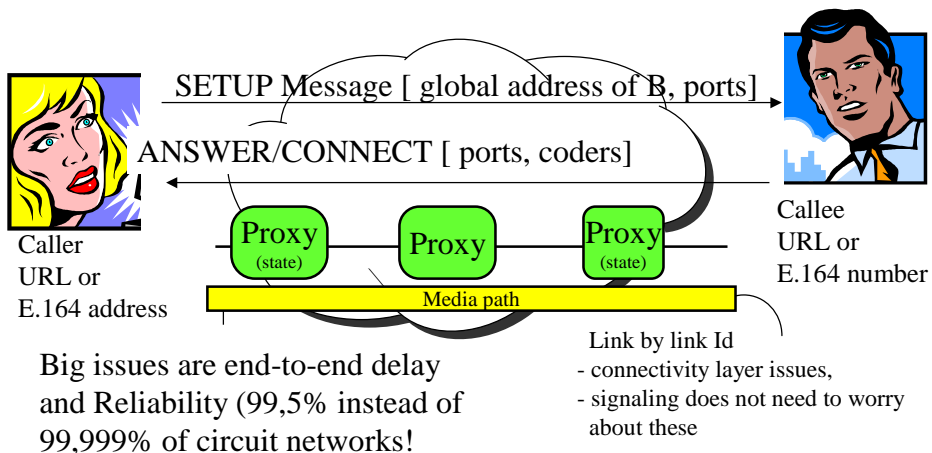

## *Connections can be set up also using network management commands*

- ✓ The PSTN can be used also for providing leased connections
- ✓ An alternative technology for leased connections e.g. for LAN-interconnection is Frame Relay which transfers variable length frames or packets. A frame carries a local address.
- ✓ Also ATM - Asynchronous Transfer Mode can be used for setting up semi-permanent virtual connections

*In this model, network nodes do not need to support any form of signaling.*

## *Life cycles of Product Generations*

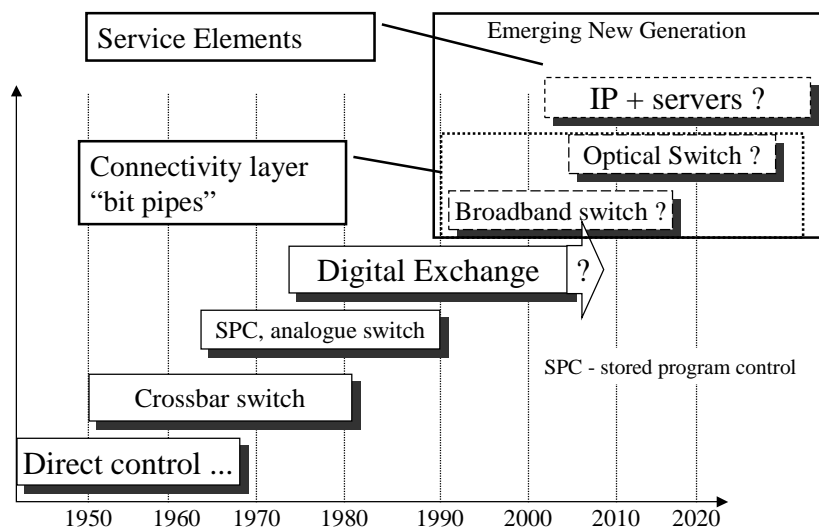

# Road map of Networking technology in Finland

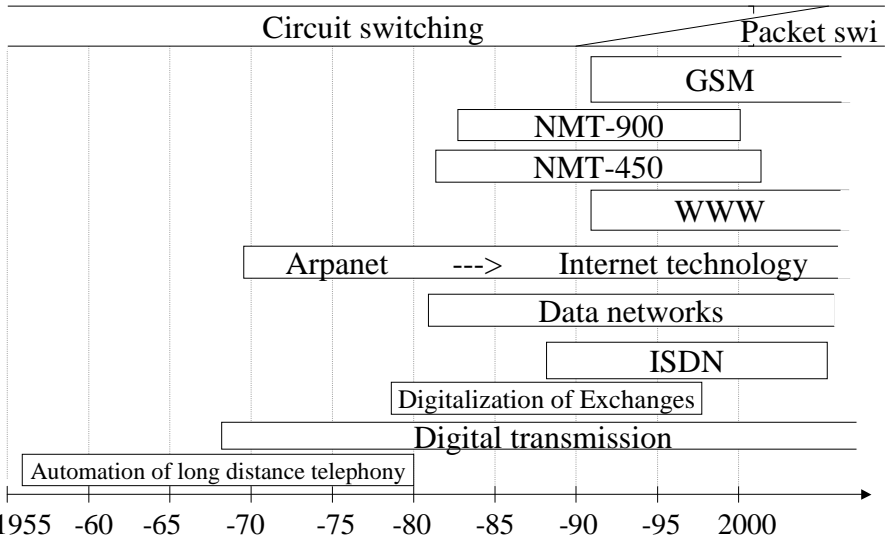

© Rka -S-2004

Signaling Protocols

1 - 31

## Summary of course scope (1)

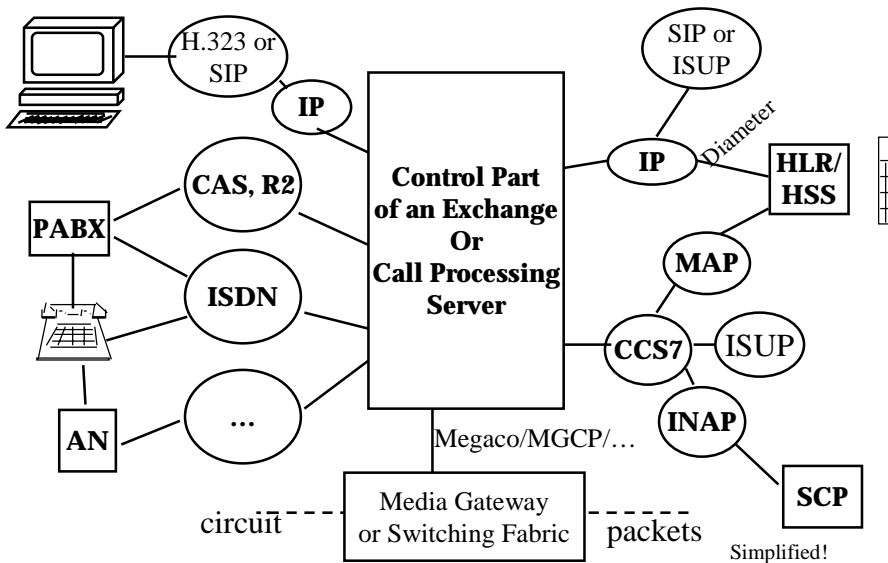

© Rka -S-2004

Signaling Protocols

1 - 32



## Summary of Course scope (2): 3G

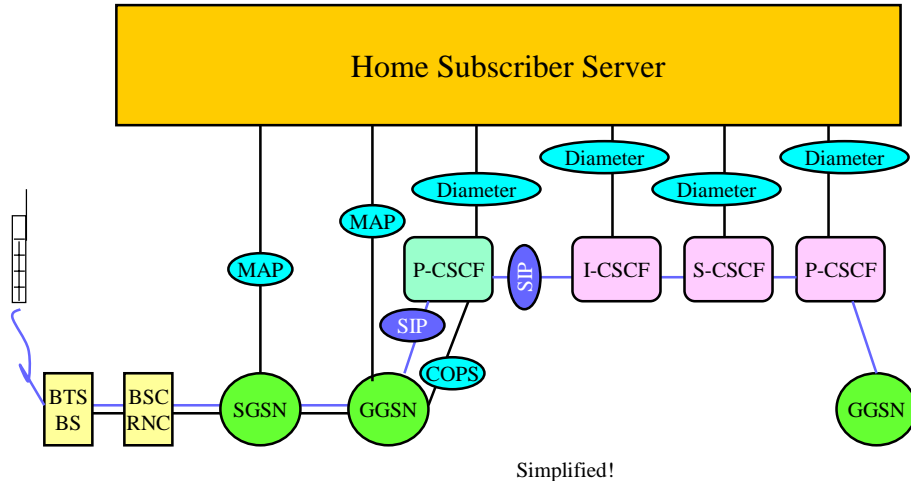

## Impact of IP Voice and IP Telephony

- ✓ **New signaling systems are needed but most of ISDN signaling properties will be reused or inherited**
- ✓ **Exchanges turn into “Call Processing Servers”.**
  - These will not have a switching fabric for voice signals
  - The Switching Fabric is replaced by the router network
  - In Peta- Giga- and Terabit routers a packet switching fabric is needed
- ✓ **Control plane (session layer) and the transport plane (connectivity layer) will be clearly separated:**
  - Calls are first set up as logical sessions and only when it is known that the parties involved can and wish to communicate the transfer of voice packets starts.
  - Voice packets and signaling typically take quite different paths.
- ✓ **Hybrid networks CS+PS with gateways.**
  - Gateway can be in the phone, intranet, Internet