

## S38.115 Signaling Protocols

- PSTN
- ✓ **Modeling of signaling systems**
    - ✓ Signaling flow charts
    - ✓ (Extended) Finite state machines
  - ✓ **Subscriber signaling**
    - ✓ Impulse code
    - ✓ Multifrequency code (DTMF - dual tone multifrequency)
  - ✓ **Trunk signaling**
    - ✓ Register signaling
    - ✓ Line signaling
  - ✓ **R2 signaling system**

## Summary of course scope

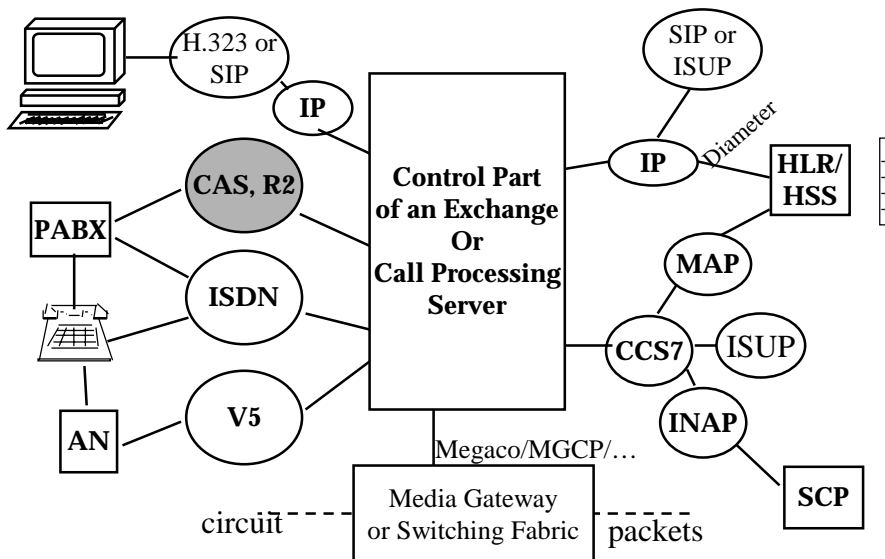

## Signaling Flow Chart illustrates the main events

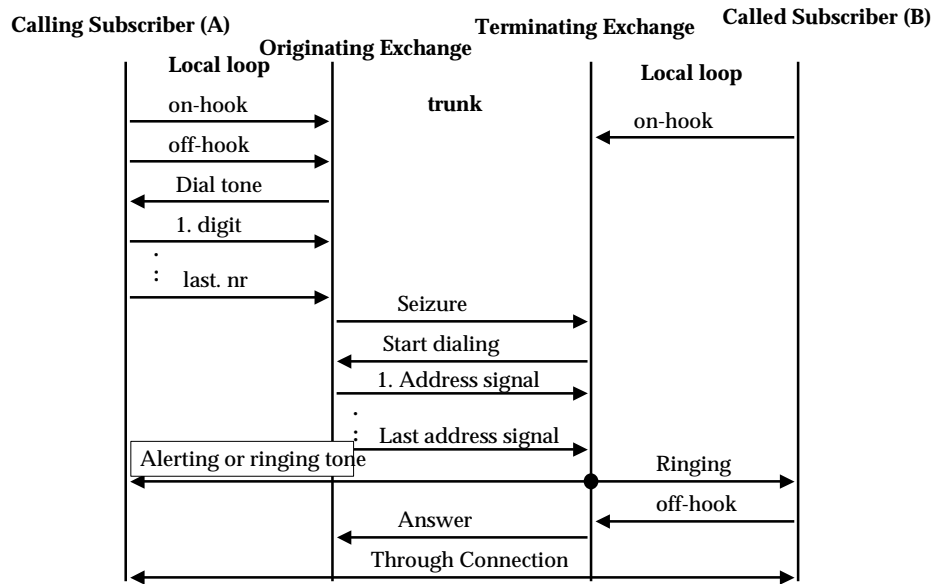

© Rka/ML -k2003

Signaling Protocols

2 - 3

## Signaling Flow Chart example cont...

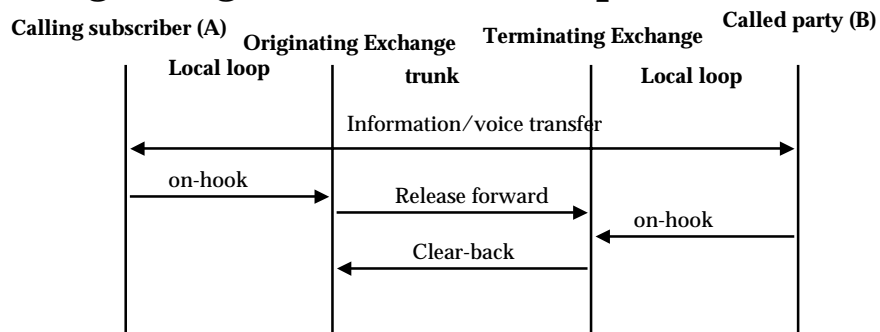

- NB: Exchanges must signal both in forward and backward direction on incoming and on outgoing side simultaneously.
- Incoming and Outgoing signaling can be separated, so can
- Incoming Call Control and Outgoing Call control.

© Rka/ML -k2003

Signaling Protocols

2 - 4

## Extended Finite State Machine is very suitable for modeling signaling senders and receivers.

Algebraic representation

$\langle s_0, I, O, U, S, f_s, f_o, f_u \rangle$

$s_0$  - initial state  
 $I$  - set of incoming signals  
 $O$  - set of outgoing signals  
 $S$  - Set of States  
 $U$  - Set of values of state variables  
 $f_s : (S \times I \times U) \rightarrow S$  - next state  
 $f_o : (S \times S) \rightarrow O$  - outgoing signal  
 $f_u : (S \times S) \rightarrow u_s \subset U$  - new values of state variables

$I_s \subset I$  - set of possible incoming signals in state  $s$

$i \in I_s$  can be unique in the signaling system or context dependent.

## Graphical representation of an FSM

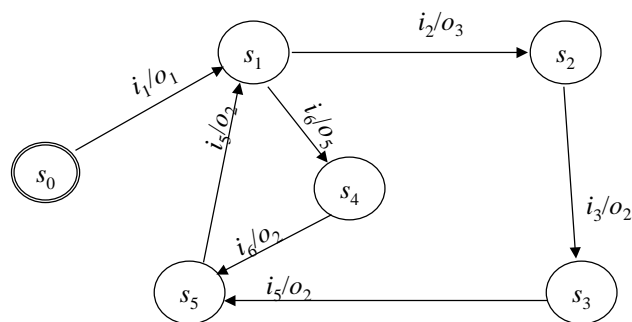

FSM - Finite State Machine

The use of FSMs is well known also in computer languages e.g. for lexical analysis. In this course it turns out that all most important real time programs in a Switching Systems are FSMs or sets of FSMs.

## SDL representation of an FSM

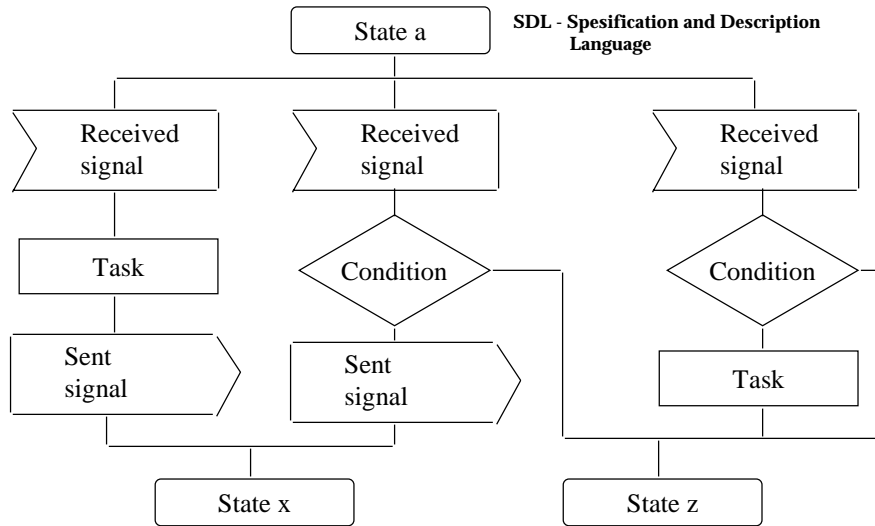

## A subscriber as an SDL -state machine

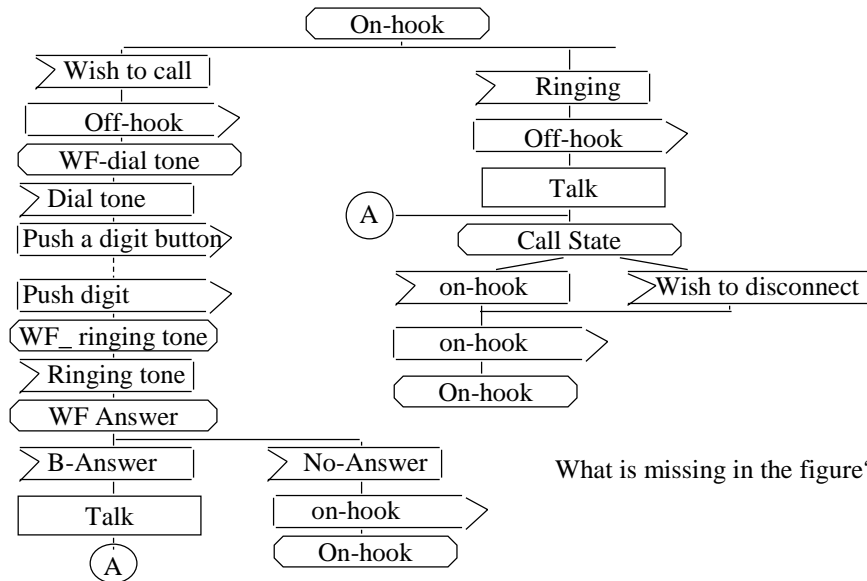

What is missing in the figure??

## *You can model the world like this*

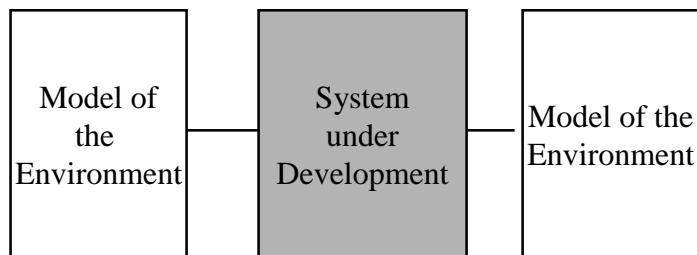

- Can use verification tools to debug your design.

## *Execution models of FSM programs*

```
Initialisation
Do Forever
    Receive Message
    A <- Branch (State, (Secondary state,) Message)
    Execute Transition (A)
Od
```

- Execution model 1: Complete the current Transition always before starting anything else (non-pre-emptive scheduling)
- Execution model 2: A Transition can be interrupted at any time if there is a new task with higher priority (pre-emptive scheduling)
- Depending on implementation a Transition may or may not contain a new (secondary) Receive Message Statement.

## *Table representation of an FSM*

| Current State | Next State      |       |       |
|---------------|-----------------|-------|-------|
|               | Incoming signal |       |       |
|               | $i_0$           | $i_1$ | $i_2$ |
| $s_0$         | $s_1$           | $s_0$ | $s_0$ |
| $s_1$         | $s_1$           | $s_2$ | $s_1$ |
| $s_2$         |                 |       |       |

## *Signaling is used to allocate network resources for the call*

- ✓ Signaling carries control information from the end user and another exchange. The info implies that certain circuits and devices in the exchange need to change state.
- ✓ Call state includes records on all resources allocated for the call (time slots, signal receivers and senders, memory, processes, records etc). It is vital that all resources are released when the call is released.
- ✓ Signals can be decadic impulses, voice band tones or binary signals or messages transported in a packet network.
- ✓ Signals transferred on a local loop between a terminal and the local exchange form *subscriber signaling*.
- ✓ When two exchanges send and receive signals we talk about *trunk signaling* (inter-exchange signaling, inter-carrier signaling etc...).

## *A Signaling System*

- ✓ A signaling system is a given  $\langle s_0, I, O, U, S, f_s, f_o, f_u \rangle$ .
- ✓ One of the key structural properties of a signaling system is, *how signaling information is associated with the voice path.*
- ✓ In the PSTN, depending on penetration of digital exchanges, the following types of signaling are used:

| Network  | Loop signaling                                      | Trunk signaling                      |
|----------|---|--------------------------------------|
| Analogue | Pulse- and multi-frequency                          | Channel Associated                   |
| Digital  | Pulse- and multi-frequency                          | Common Channel                       |
| ISDN     | DSS1 (Q.920...Q.931)<br>(digital sign systems nr 1) | Common Channel Signaling<br>(CCS #7) |

## *Subscriber or loop signaling*

- ✓ The terminal (a phone) sends information to the network in either rotary impulses or in Dual-Tone-Multi-frequency (DTMF-) signals.
- ✓ A DTMF-signal has two frequencies out of six.
- ✓ Such Frequencies are used that they have no harmonic components with the other frequencies:
  - Good immunity to voice signals (incl. whistling) is achieved
  - No interference between dial tone and the first digit
  - Impact of local loop is minimized (attenuation is proportional to square root of frequency)

*DTMF-signals are created with a push button phone*

|       | 1209Hz   | 1336Hz   | 1447Hz   | 1633Hz   |
|-------|----------|----------|----------|----------|
| 697Hz | <b>1</b> | <b>2</b> | <b>3</b> | <b>A</b> |
| 770Hz | <b>4</b> | <b>5</b> | <b>6</b> | <b>B</b> |
| 852Hz | <b>7</b> | <b>8</b> | <b>9</b> | <b>C</b> |
| 941Hz | <b>*</b> | <b>0</b> | <b>#</b> | <b>D</b> |

*Impulse signals are created by the rotary disk*

- ✓ Impulses are created by cutting and reconnecting the local loop (current on and off).
- ✓ On/off states in an impulse are 40 and 60 ms.
- ✓ The number of such impulses is a telephony signal, e.g. digit 3.
- ✓ Between two signals an interval of 400-800 ms is used to separate signals.
- ✓ Signals are created on the backward rotation of the disk



## ***Responses to the terminal***

- ✓ Terminal receives the following indications as responses to the signals it has sent:

| Semantics    | Frequency | Timing                  |
|--------------|-----------|-------------------------|
| Dial tone    | 425 Hz    | continuous              |
| Ringing tone | 425 Hz    | 1s on, 4s silence       |
| Engaged/Busy | 425 Hz    | 300 ms on, 300 ms off   |
| Queueing     | 950 Hz    | 650 ms                  |
|              | 950 Hz    | 325 ms                  |
|              | 1400 Hz   | 1300 ms on, 2600 ms off |

In terms of modelling the signaling flow, tones are like signals. However, tones are transported in the voice band and intermediate exchanges usually do not see them!

## ***Call establishment procedure or signaling sets up the call between two parties across the network***

- ✓ Trunk signaling can be divided into two phases: call set-up control or inter-register signaling and line signaling.
- ✓ In setting up a call, devices called *incoming and outgoing register* were used in earlier exchange types, thus register signaling.
- ✓ Call set up (register phase) ends in the *ringing state*, and devices seized for the call (such as registers) are released for use by other calls.

Incoming and outgoing registers were used in crossbar and relay exchanges. In digital exchanges the same functions are performed by programs. Allocating Register phase call processing and signaling to separate programs may save memory, but will make call control more difficult during the call. When computer memory became plentiful and ISDN emerged, the separating of register and line signaling phases lost its importance.

## ***Line signaling takes care of call supervision and tear-down (release)***

- ✓ Line signaling is used to control the state of line or channel specific equipment.
- ✓ Line signaling starts when the call has been set up and call routing has been performed.
- ✓ Line signaling supervises call tear-down and may also send charging information to a charging point (Finland).
- ✓ Call signaling ends with the release commands to exchange devices and circuits that the call was using.
- ✓ Another name: supervisory signaling.
- ✓ Often physically line signals look quite different from register signals.

## ***Number Analysis links the information received from signaling to call routing***

- ✓ **Analysis result is determined by**
  - Dialed digits ( from call set up signaling)
  - Incoming circuit group,
  - Origin or subscriber category (e.g. operator - see R2 group II)
- ✓ **Analysis may return**
  - a set of routing alternatives
  - an instruction to perform number translation (e.g. 0800-numbers):  
In this case, the analysis may need to be repeated
- ✓ **Analysis trees are built by MML-commands issued by the operator based on a route plan**

## An example of route descriptions

The tree is traversed according to some algorithm until an idle outgoing circuit is found or the tree ends, in which case the call is blocked.

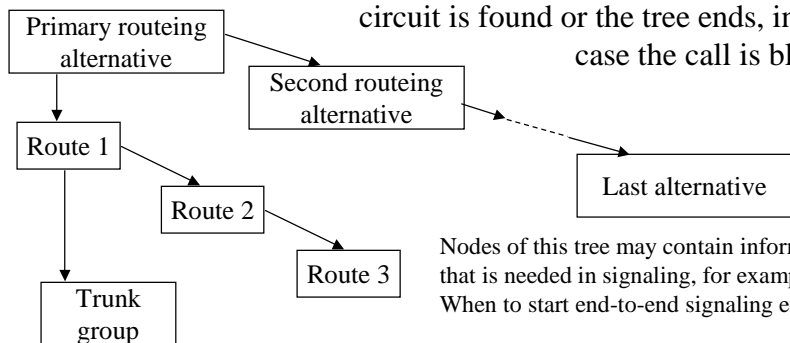

Nodes of this tree may contain information that is needed in signaling, for example: When to start end-to-end signaling etc...

*seizure = search and reservation of a free circuit or trunk*

**Outgoing circuits or trunks**

Different algorithms exist for seizure. Circuit groups can be either unidirectional or bi-directional (as comp. to call set-up)

## Some Signals used in trunk signaling

| Line/Set-up | Signal                        | Direction      |
|-------------|-------------------------------|----------------|
| L           | seizing signal                | --> (forward)  |
| L           | seizing-acknowledgement       | <-- (backward) |
| S           | request for an address signal | <--            |
| S           | address signal                | -->            |
| S           | congestion signals            | <--            |
| S           | address complete signals      | <--            |
| S           | subscriber free (charge)      | <--            |
| S           | subscriber free (no charge)   | <--            |
| S           | subscriber line busy          | <--            |
| L           | answer signal                 | <--            |
| L           | charging pulse                | <--            |
| L           | clear-back signal             | <--            |
| L           | release-guard signal          | <--            |
| L           | clear-forward                 | -->            |
| L           | blocking                      | <--            |
| L           | remove blocking               | <--            |

## ***Channel Associated Signaling (CAS)***

- ✓ Is originally based on properties of electrical circuits typical in crossbar and relay exchanges.
- ✓ In Channel Associated signaling the association of the voice path with the signal path may be based on space or frequency or time division multiplexing.
  - **Space division:** each voice copper pair is associated with a signaling copper pair. Wastes a lot of copper, therefore, different multiplexing schemes have been developed.
  - **In frequency and time division multiplexing (TDM),** the location of the signaling channel determines the associated voice channel. PCM (pulse code multiplexing) is an example of a TDM system, that uses *time-slot 16* to carry signaling of the voice channels. A multi-frame structure is used to establish the association between the voice and the signaling channels.

## ***R2 and N2***

- ✓ Among CAS systems, in Finland, the most widely spread is probably R2. A CAS system called N2, developed by Siemens was also widely used especially by the Helsinki Telephone Company.
- ✓ R2 is the most powerful among analogue CAS systems and was originally specified by ITU-T and elaborated by national standardization.
- ✓ R2 is a *forward and backward compelled* signaling system. Sender continues sending a signal until it sees an acknowledgement signal from the the other end. This ensures reliable and fast operation.

## *Compelled signaling method*

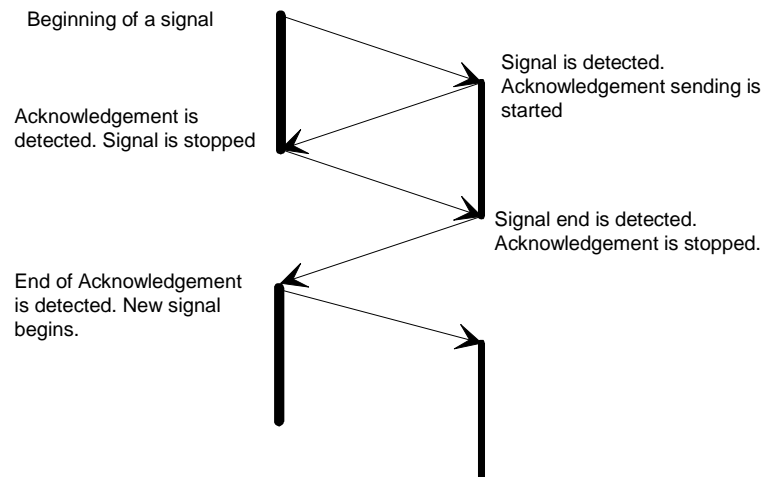

## *R2 and carriage of signals*

- ✓ R2 - system is based on end-to-end signaling. Intermediate exchanges just pick the information they need for routing the call, then they through connect the voice path and the rest of the signals can travel transparently onwards.
- ✓ R2 uses MF -coding, in which a signal is a combination of two voice band frequencies. Both forward and backward directions have their own set of six frequencies producing 15 possible signals in both directions.
- ✓ These signals are grouped into two subgroups (I.e. each physical signal is used twice!) the use of which is controlled by the receiving end.

## *'Forward'-signals*

| Signal | Group I                   | Group II                 |
|--------|---------------------------|--------------------------|
| 1      | 1                         | Ordinary subscriber      |
| 2      | 2                         | Subscriber with priority |
| 3      | 3                         | Test call                |
| 4      | 4                         | Coin box                 |
| 5      | 5                         | Operator                 |
| 6      | 6                         | Data transmission call   |
| 7      | 7                         | Ordinary subscriber      |
| 8      | 8                         | Data transmission call   |
| 9      | 9                         | Priority extension       |
| 10     | 0                         | Operator                 |
| 11     | Special serv operator     | Forwarded call           |
| 12     | Negative ack              | National signal          |
| 13     | Test equipment            | National signal          |
| 14     | Network Operator specific | National signal          |
| 15     | End of pulsing            | National signal          |

## *'Backward'-signals*

| Signal | Group A                                 | Group B                         |
|--------|---|---------------------------------|
| 1      | Send next digit                         | subscriber line free            |
| 2      | Repeat last but one address signal      | Send special info tone          |
| 3      | <b>Hop to receiving Group B signals</b> | subscriber line busy            |
| 4      | Congestion in national network          | Congestion                      |
| 5      | <b>Send A-subscriber category</b>       | unallocated number              |
| 6      | Connect to voice path                   | subscriber line free, charge    |
| 7      | Repeat number n - 2                     | subscriber line free, no charge |
| 8      | Repeat number n - 3                     | subscriber line out of order    |
| 9      | Send country code of A-sub              | reroute to operator             |
| 10     | Network Operator Specific               | subscriber number changed       |

NB: Because of many variants, the exact signals may be different in different implementations. Naturally, both ends need to follow exactly the same implementation!

## PCM-frame structure

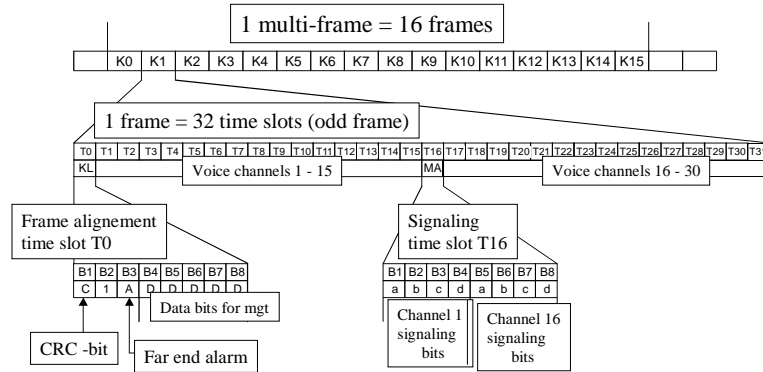

## Even numbered PCM 30-frame

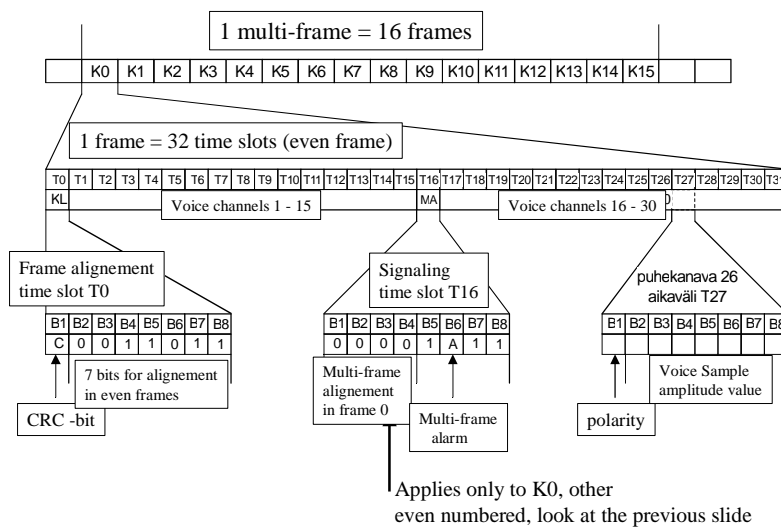

## *R2 - line signals*

- ✓ There are a number of variants of Line signaling for R2. A typical variant in Finland was (is) PCM -line signals. PCM -line signals are sent in timeslot 16 of the PCM -frame, so that the four bits (a, b, c, d) in the multi-frame dedicated to the corresponding voice channel are used as follows:

|                  | Signal           | a | b | c | d | a | b | c | d |
|------------------|------------------|---|---|---|---|---|---|---|---|
|                  | Idle             | 1 | 0 | 0 | 1 | 1 | 0 | 0 | 1 |
|                  | Seizure          | 0 | 0 | 0 | 1 | 1 | 0 | 0 | 1 |
| NB first abcd    | Seizing ack      | 0 | 0 | 0 | 1 | 1 | 1 | 0 | 1 |
| are forward bits | B-answer         | 0 | 0 | 0 | 1 | 0 | 1 | 0 | 1 |
| second abcd are  | Charging         | 0 | 0 | 0 | 1 | 1 | 0 | 0 | 1 |
| backward bits    | B off-hook       | 0 | 0 | 0 | 1 | 1 | 1 | 0 | 1 |
|                  | Clear-back       | 0 | 0 | 0 | 1 | 0 | 0 | 0 | 1 |
|                  | Clear-forward    | 1 | 0 | 0 | 1 | 1 | 1 | 0 | 1 |
|                  | Clear forward    | 1 | 0 | 0 | 1 | 0 | 1 | 0 | 1 |
|                  | Clear forward    | 1 | 0 | 0 | 1 | 0 | 0 | 0 | 1 |
|                  | Blocking         | 1 | 0 | 0 | 1 | 1 | 1 | 0 | 1 |
|                  | forward-transfer | 0 | 1 | 0 | 1 | 1 | 1 | 0 | 1 |

## *Signaling after set-up of the call*

- ✓ It is typical in CAS systems that after setting up the call, terminals can not control the network in any way except initiate release.
- ✓ This is due to closing the signaling “connection” between the phone and the local exchange.
- ✓ Workaround methods have been developed. An LE can supervise the voice channel traffic and possible DTMF signals on the voice path or the line card can detect “polarity reversal”.
  - It must be possible to detect DTMF -signals among voice.
  - Polarity reversal can cause seizure of a register during a call.



## *Limitations of analogue signaling systems*

- ✓ **Only a small set of signals -> difficult to add new services.**
- ✓ **Context dependent semantics of signals --> modularization of programs is difficult.**
- ✓ **Signaling FSM controls the state of Exchange resources on a micro -level --> complex call control..**
- ✓ **Separate, e.g. DSPs are needed for signal detection and translation of R2 and DTMF signals.**
- ✓ **Voice channel and signaling channel have a fixed mapping. No signaling unless voice channel has been seized.**
- ✓ **Difficult to control the call after the setup.**
- ✓ **A lot of national and vendor specific variants.**